

imc ARGUSfit

Manual

Edition 5 - 2024-07-04

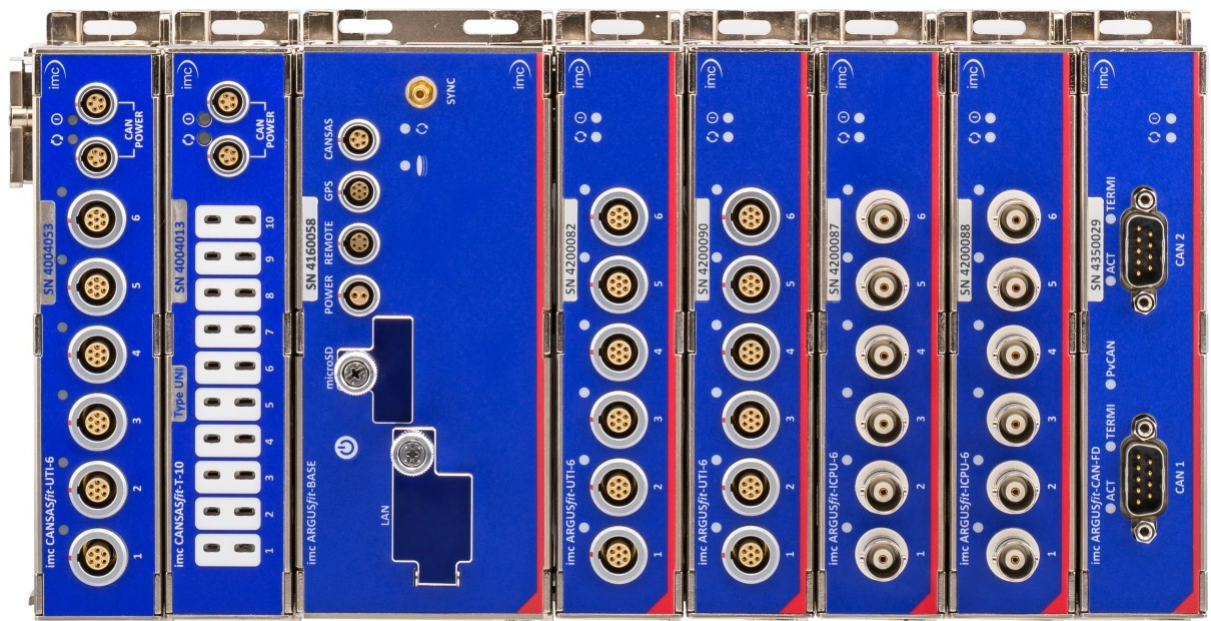

Disclaimer of liability

The contents of this documentation have been carefully checked for consistency with the hardware and software systems described. Nevertheless, it is impossible to completely rule out inconsistencies, so that we decline to offer any guarantee of total conformity.

We reserve the right to make technical modifications of the systems.

Copyright

© 2024 imc Test & Measurement GmbH, Germany

This documentation is the intellectual property of imc Test & Measurement GmbH. imc Test & Measurement GmbH reserves all rights to this documentation. The applicable provisions are stipulated in the "imc Software License Agreement".

The software described in this document may only be used in accordance with the provisions of the "imc Software License Agreement".

Open Source Software Licenses

Some components of imc products use software which is licensed under the GNU General Public License (GPL). Details are available in the About dialog.

A list of the open source software licenses for the imc measurement devices is located on the imc STUDIO/imc WAVE/imc STUDIO Monitor installation medium in the folder "*Products\imc DEVICES\OSS*" or "*Products\imc DEVICEcore\OSS*" or "*Products\imc STUDIO\OSS*". If you wish to receive a copy of the GPL sources used, please contact our tech support.

Notes regarding this document

This document provides important notes on using the device / the module. Safe working is conditional on compliance with all safety measures and instructions provided. The manual is to be used as a kind of reference book. You can skip the description of the modules you do not have.

Additionally, all accident prevention and general safety regulations pertinent to the location at which the device is used must be adhered to.

These instructions exclusively describe the device, **not how to operate** it by means of **the software!**

If you have any questions as to whether you can set up the device / module in the intended environment, please contact our tech support. The measurement system has been designed, manufactured and unit-tested with all due care and in accordance with the safety regulations before delivery and has left the factory in perfect condition. In order to maintain this condition and to ensure safe operation, the user must observe the notes and warnings contained in this chapter and in the specific sections applicable to the concrete device. Never use the device outside the specification.

This will protect you and prevent damage to the device.

Special notes

Warning

Warnings contain information that must be observed to protect the user from harm or to prevent damage to property.

Note

Notes denote useful additional information on a particular topic.

Reference

A reference in this document is a reference in the text to another text passage.

Table of contents

1 General introduction	6
1.1 Tech support	6
1.2 Service and maintenance	6
1.3 Legal notices	6
1.4 Explanation of symbols	9
1.5 History	10
2 Safety	11
3 Assembly and connection	14
3.1 After unpacking...	14
3.2 Before commissioning	14
3.3 Notes on connecting	15
3.3.1 Precautions for operation	16
3.3.2 Click mechanism	17
3.3.3 Using CANFT modules	18
3.3.4 Power supply	20
3.3.5 Fiber Converter	21
3.3.6 UPS-NiMH	22
3.3.7 Powering on	26
3.3.8 Powering off	26
3.3.9 Remote control of the base unit	26
3.3.10 Storage media in the device	27
3.3.11 LED display ARGFT-BASE	30
4 Maintenance and servicing	32
4.1 Maintenance and servicing	32
4.2 Cleaning	32
4.3 Storage	32
4.4 Transport	32
5 Start of operation Software / Firmware	33
5.1 Installation - Software	33
5.1.1 System requirements	33
5.2 Connect the device	33
5.3 Connecting via LAN in three steps	34
5.4 Firmware update	36
6 Properties	38
6.1 Device overview	38
6.2 Device description	39
6.2.1 Mechanical dimensions	40
6.2.2 Included accessories	41
6.2.3 Optional accessories	41
6.2.4 GPS	42
6.2.5 Synchronization	44
6.2.6 Filter settings	45
7 Measurement types	54
7.1 Temperature measurement	54
7.1.1 Thermocouples as per DIN and IEC	54

7.1.2 PT100 (RTD) - measurement	54
7.2 Bridge measurement	55
7.2.1 Definition of terms	55
7.2.2 Quarter bridge	57
7.2.3 Half bridge	59
7.2.4 Full bridge	61
8 Measurement modules	64
8.1 B-4	64
8.1.1 Bridge measurement	64
8.1.2 Sense wires	66
8.1.3 Sensor supply	66
8.1.4 Adjustment of the pre-trim	67
8.1.5 Balancing and shunt calibration	68
8.1.6 Voltage measurement	69
8.2 UTI-6	70
8.2.1 Voltage measurement	70
8.2.2 Current measurement	71
8.2.3 Resistance measurement	72
8.2.4 RTD measurement	73
8.2.5 Sensor supply	74
8.3 ICPU-6	75
8.3.1 Voltage measurement	75
8.3.2 Current fed sensors	75
8.4 CAN FD	76
9 Technical Specs	80
9.1 Operating conditions of the measurement modules	80
9.2 Base unit - Technical Specs	81
9.3 B-4 - Technical Specs	86
9.4 UTI-6 - Technical Specs	91
9.5 ICPU-6 - Technical Specs	96
9.6 Expansions	101
9.6.1 Fiber Converter - Technical Specs	101
9.6.2 UPS-NiMH - Technical Specs	103
9.6.3 CAN bus - Technical Specs	105
10 Pin configuration	107
10.1 Power	107
10.2 Remote	107
10.3 Base Unit	108
10.3.1 GPS	108
10.3.2 CANSAS	108
10.4 Measurement Modules	109
10.4.1 B-4	109
10.4.2 UTI-6	109
10.4.3 ICPU-6	109
10.4.4 CAN FD (DSUB-9)	110
Index	112

1 General introduction

1.1 Tech support

If you have problems or questions, please contact our tech support:

Phone: (Germany): **+49 30 467090-26**
E-Mail: hotline@imc-tm.de
Internet: <https://www.imc-tm.com/service-training/>

Tip for ensuring quick processing of your questions:

If you contact us **you would help us**, if you know the **serial number of your devices** and the **version info of the software**. This documentation should also be on hand.

- The device's serial number appears on the nameplate.
- The program version designation is available in the About-Dialog.

Product Improvement and change requests

Please help us to improve our documentation and products:

- Have you found any errors in the software, or would you suggest any changes?
- Would any change to the mechanical structure improve the operation of the device?
- Are there any terms or explanations in the manual or the technical data which are confusing?
- What amendments or enhancements would you suggest?

Our [tech support](#) will be happy to receive your feedback.

1.2 Service and maintenance

Our service team is at your disposal for service and maintenance inquiries:

E-Mail: service@imc-tm.de
Internet: <https://www.imc-tm.com/service>

Service and maintenance activities include, for example calibration and adjustment, service check, repairs.

1.3 Legal notices

Quality Management



imc Test & Measurement GmbH holds DIN EN ISO 9001 certification since May 1995 and DIN EN ISO 14001 certification since November 2023. You can download the CE Certification, current certificates and information about the imc quality system on our website:

<https://www.imc-tm.com/quality-assurance/>.

imc Warranty

Subject to the general terms and conditions of imc Test & Measurement GmbH.

Liability restrictions

All specifications and notes in this document are subject to applicable standards and regulations, and reflect the state of the art well as accumulated years of knowledge and experience. The contents of this document have been carefully checked for consistency with the hardware and the software systems described. Nevertheless, it is impossible to completely rule out inconsistencies, so that we decline to offer any guarantee of total conformity. We reserve the right to make technical modifications of the systems.

The manufacturer declines any liability for damage arising from:

- failure to comply with the provided documentation,
- inappropriate use of the equipment.

Please note that all properties described refer to a closed measurement system and not to its individual slices. Attach covers over the [module connectors](#)  on the upper and lower sides.

Guarantee

Each device is subjected to a 24-hour "burn-in" before leaving imc. This procedure is capable of detecting almost all cases of early failure. This does not, however, guarantee that a component will not fail after longer operation. Therefore, all imc devices are granted liability for a period of two years. The condition for this guarantee is that no alterations or modifications have been made to the device by the customer.

Unauthorized intervention in the device renders the guarantee null and void.

Notes on radio interference suppression

imc ARGUSfit devices satisfy the EMC requirements for an use in industrial settings.

Any additional products connected to the product must satisfy the EMC requirements as specified by the responsible authority (within Europe¹) in Germany the BNetzA - "Bundesnetzagentur" (formerly BMPT-Vfg. No. 1046/84 or No. 243/91) or EC Guidelines 2014/30/EU. All products which satisfy these requirements must be appropriately marked by the manufacturer or display the CE certification marking.

Products not satisfying these requirements may only be used with special approval of the regulating body in the country where operated.

All lines connected to the imc ARGUSfit should not be longer than 30 m and they should be shielded and the shielding must be grounded.

Note

The EMC tests were carried out using shielded and grounded input and output cables with the exception of the power cord. Observe this condition when designing your setup to ensure high interference immunity and low jamming.

¹ If you are located outside Europe, please refer the appropriate EMC standards used in the country of operation.

Cables and leads

In order to comply with the value limits applicable to Class B devices according to part 15 of the FCC regulations, all signal leads connected to imc ARGUSfit must be shielded.

Unless otherwise indicated, no connection leads may be long leads (< 30 m) as defined by the standard IEC 61326-1. LAN-cables (RJ 45) and CAN-Bus cables are excepted from this rule.

Only cables with suitable properties for the task (e.g. isolation for protection against electric shock) may be used.

ElektroG, RoHS, WEEE, CE

The imc Test & Measurement GmbH is registered with the authority as follows:

WEEE Reg. No. DE 43368136

valid from 24.11.2005



Reference

<https://www.imc-tm.com/elekrog-rohs-weee/> and <https://www.imc-tm.com/ce-conformity/>

FCC-Notice

This product has been tested and found to comply with the limits for a Class B digital device, pursuant to Part 15 of the FCC Rules. These limits are designed to provide reasonable protection against harmful interference in a residential installation. This equipment generates, uses, and can radiate radio frequency energy and, if not installed and used in accordance with the instructions, may cause harmful interference to radio communications. However, there is no guarantee that interference will not occur in a particular installation. If this equipment does cause harmful interference to radio or television reception, which can be determined by turning the equipment on and off, the user is encouraged to try to correct the interference by one or more of the following measures:

- Reorient or relocate the receiving antenna.
- Increase the separation between the equipment and the receiver.
- Connect the equipment into an outlet on a circuit different from that to which the receiver is connected.
- Consult our tech support or an experienced technician for help.

Modifications

The FCC requires the user to be notified that any changes or modifications made to this product that are not expressly approved by imc may void the user's authority to operate this equipment.

1.4 Explanation of symbols



CE Conformity

see CE [chapter 1.2](#)



No household waste

Please do not dispose of the electrical/electronic device with household waste, but at the appropriate collection points for electrical waste, see also [chapter 1.2](#).



Potential compensation

Connection for potential compensation



Grounding

Connection for grounding (general, without protective function)

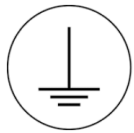

Protective connection

Connection for the protective conductor or grounding with protective function



Attention! General danger zone!

This symbol indicates a dangerous situation;
Since there is insufficient space for indicating the rated quantity at the measuring inputs, refer to this manual for the rated quantities of the measuring inputs before operation.



Attention! Injuries from hot surfaces!

Surfaces whose temperatures can exceed the limits under certain circumstances are denoted by the symbol shown at left.



ESD-sensitive components (device/connector)

When handling unprotected circuit boards, take suitable measures to protect against ESD (e.g. insert/remove ACC/CANFT-RESET).



Possibility of electric shock

The warning generally refers to high measurement voltages or signals at high potentials and is located on devices suitable for such measurements. The device itself does not generate dangerous voltages.



DC, Direct Current

Supply of the device via a DC voltage source (in the specified voltage range)



RoHS of the PR China

The limits for hazardous substances in electrical/electronic equipment applicable in the PRC are identical to those in the EU. The restrictions are complied with (see [chapter 1.2](#)). A corresponding "China-RoHS" label is omitted for formal/economic reasons. Instead, the number in the symbol indicates the number of years in which no hazardous substances are released. (This is guaranteed by the absence of named substances).



Labeling integrated energy sources

UxxRxx are integrated in the symbolism. "U" stands for the installed UPS energy sources, if 0 = not installed. "R" stands for the installed RTC energy sources, if 0 = not installed. You can download the corresponding data sheets from the imc website:

<https://www.imc-tm.com/about-imc/quality-assurance/transport-instructions/>



Observe the documentation

Read the documentation before starting work and/or operating.



On/Off

On/Off button (no complete disconnection from the power supply)

1.5 History

Amendments and bug-fix in this Manual Edition 4

Section	Amendments
B-4	new module added: ARGFT/B-4
Storage media	updated description

Amendments and bug-fix in Edition 3

Section	Amendments
GPS	as of imc STUDIO 2023 R5 the GPS functionality is fully supported

Amendments and bug-fix in Edition 2

Section	Amendments
CAN FD	new module added: ARGFT/CAN FD

2 Safety

This section provides an overview of all important aspects of protection of the users for reliable and trouble-free operation. Failure to comply with the instructions and protection notes provided here can result in serious danger.

Responsibility of the operator

imc ARGUSfit is for use in commercial applications. The user is therefore obligated to comply with legal regulations for work safety.

Along with the work safety procedures described in this document, the user must also conform to regulations for safety, accident prevention and environmental protection which apply to the work site. If the product is not used in a manner specified by the manufacturer, the protection supported by the product may be impaired.

The user must also ensure that any personnel assisting in the use of the imc ARGUSfit have also read and understood the content of this document.

Operating personnel

This document identifies the following qualifications for various fields of activity:

- *Users of measurement engineering*: Fundamentals of measurement engineering. Basic knowledge of electrical engineering is recommended. Familiarity with computers and the Microsoft Windows operating system. Users must not open or structurally modify the measurement device.
- *Qualified personnel* are able, due to training in the field and to possession of skills, experience and familiarity with the relevant regulations, to perform work assigned while independently recognizing any hazards.

Warning

- **Danger of injury due to inadequate qualifications!**
- Improper handling may lead to serious damage to personnel and property. When in doubt, consult qualified personnel.
- Work which may only be performed by trained imc personnel may not be performed by the user. Any exceptions are subject to prior consultation with the manufacturer and are conditional on having obtained corresponding training.

Special hazards

This segment states what residual dangers have been identified by the hazard analysis. Observe the safety notes listed here and the warnings appearing in subsequent chapters of this manual in order to reduce health risks and to avoid dangerous situations. Please operate the device only in the intended position of use if so specified.

Danger



Lethal danger from electric current!

- Contact with conducting parts is associated with immediate lethal danger.
- Damage to the insulation or to individual components can be lethally dangerous.

Therefore:

- In case of damage to the insulation, immediately cut off the power supply and have repair performed.
- Work on the electrical equipment must be performed exclusively by expert electricians.
- During all work performed on the electrical equipment, it must be deactivated and tested for static potential.

Injuries from hot surfaces!



- Devices from imc are designed so that their surface temperatures do not exceed limits stipulated in EN 61010-1 under normal conditions.

Therefore:

- Surfaces whose temperature can exceed the limits under circumstances are denoted by the symbol shown at left.

Industrial safety

We certify that imc ARGUSfit in all product configuration options corresponding to this documentation conforms to the directives in the accident prevention regulations in "Electric Installations and Industrial Equipment" (DGUV Regulation 3)*. This confirmation applies exclusively to devices of the imc ARGUS series, but not to all other components included in the scope of delivery.

This certification has the sole purpose of releasing imc from the obligation to have the electrical equipment tested prior to first use (§ 5 Sec. 1, 4 of DGUV Regulation 3). This does not affect guarantee and liability regulations of the civil code.

* previously BGV A3.

Observe notes and warnings

Devices from imc have been carefully designed, assembled and routinely tested in accordance with the safety regulations specified in the included certificate of conformity and has left imc in perfect operating condition. To maintain this condition and to ensure continued danger-free operation, the user should pay particular attention to the remarks and warnings made in this chapter. In this way, you protect yourself and prevent the device from being damaged.

Read this document before turning on the device for the first time carefully.



Warning

Before touching the device sockets and the lines connected to them, make sure static electricity is diverted to ground. Damage arising from electrostatic discharge is not covered by the warranty.

3 Assembly and connection

3.1 After unpacking...

Check the delivered system immediately upon receiving it for completeness and for possible transport damage. In case of damage visible from outside, proceed as follows:

- Do not accept the delivery or only accept it with reservations
- Note the extent of the damage on the packing documents or on the delivery service's packing list.
- Begin the claims process.

For an overview of the accessories supplied as standard, please refer to the data sheet of the supplied ARGUSfit module. Check the accessories for completeness.

Note

File a claim about every fault as soon as it is detected. Claims for damages can only be honored within the stated claims period.

3.2 Before commissioning

Condensation may form on the circuit boards when the device is moved from a cold environment to a warm one. In these situations, always wait until the device warms up to room temperature and is completely dry before turning it on. The acclimatization period should take about 2 hours.

Ambient temperature

The limits of the ambient temperature cannot be strictly specified because they depend on many factors of the specific application and environment, such as air flow/convection, heat radiation balance in the environment, contamination of the housing / contact with media, mounting structure, system configuration, connected cables, operating mode, etc. This is taken into account by specifying the operating temperature instead. Furthermore, it is not possible to predict any sharp limits for electronic components. Basically, reliability decreases when operating under extreme conditions (forced ageing). The operating temperature data represent the extreme limits at which the function of all components can still be guaranteed.

3.3 Notes on connecting

In the following chapters we use the block representation of the modules and not the original photos to illustrate the application examples.

Legend:

 	 
 	 
<p>imc ARGUSfit provides a complete integration of the imc CANSASfit module series (CANFT) for slower channels, e.g. for temperature measurement.</p>	 

3.3.1 Precautions for operation

Certain general rules for operating the system, aside from reasonable safety measures, must be observed to prevent danger to the user, third parties, the device itself and the measurement object. These are the use of the system in conformity to its design, and the refraining from altering the system, since possible later users may not be properly informed and may ill-advisedly rely on the precision and safety promised by the manufacturer.

Note

If you determine that the device cannot be operated in a safe manner, then the device is to be immediately taken out of operation and protected from unintentional use. Taking this action is justified under any of the following conditions:

- I. the device is visibly damaged,
- II. loose parts can be heard within the device,
- III. the device does not work
- IV. the device has been stored for a long period of time under unfavorable conditions (e.g. outdoors or in high-humidity environments).

1. Observe the data in the manual chapter "Technical Specifications", to prevent damage to the unit through inappropriate signal connection.
2. Note when designing your setups that all input and output leads must be provided with shielding which is connected to the ground (see notification on the nameplate) at one end in order to ensure high immunity to interference and noisy transmission.
3. Unused, open channels (having no defined signal) should not be configured with sensitive input ranges. Configure unused channels with a broad input range or short them out. The same applies to channels not configured as active.
4. If you are using a removable storage media, observe the notes in the imc software manual. Particular care should be taken to comply with the storage device's max. ambient temperature limitation.
5. Avoid prolonged exposure of the device to sunlight.

Due to their function, the imc ARGUSfit modules, just like the CANSASfit modules, are open at the connection points (module connectors). This is not a problem when used in a controlled, dry environment. In order to protect a module (or even a group connected in series) against foreign objects and moisture, please carry out the following measure:

Attach both protective caps across the module click connectors on the upper and lower sides.

Two covers per module are fixed at the left side of the module (*parking position*).

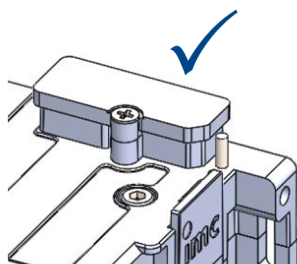

module connector protected
with covering cap

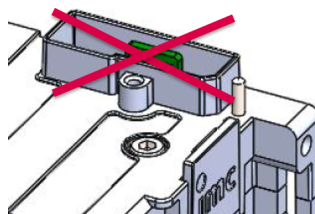

module connector
not protected

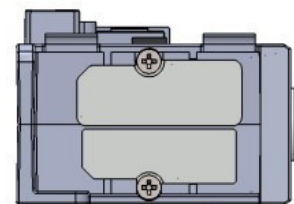

Fig. 1: parking position of
covering caps

3.3.2 Click mechanism

imc ARGUSfit (ARGFT) modules and imc CANSASfit (CANFT) modules can be mechanically and electrically connected by a click-lock, without tools and without additional connecting cables. Before you start connecting the modules together, make sure that no supply voltage is connected.

The CANFT Module are connected to the system **on the left side of the ARGFT base unit**, see Fig. 2.

ARGFT
base unit

ARGFT modules are connected to the system **on the right side of the ARGFT base unit**. Further rules, see [Fiber converter](#)^[21] and [UPS](#)^[22]

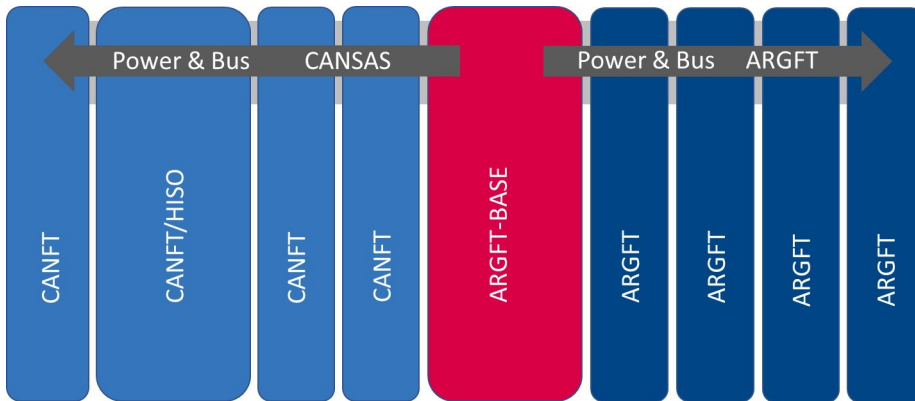

Fig. 2: Order of possible Click connections

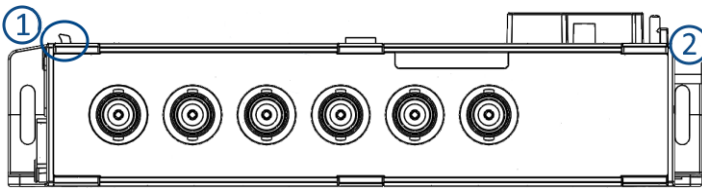

Fig. 3: Locking tongue & locking latch

Stacking the modules

1. Hook tongues into the grooves, see Fig. 3 Position (1) "tongue".
2. Press modules together

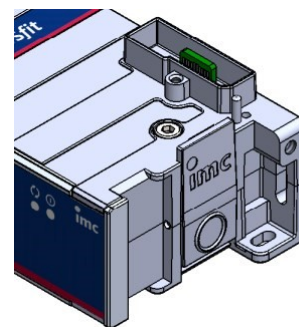
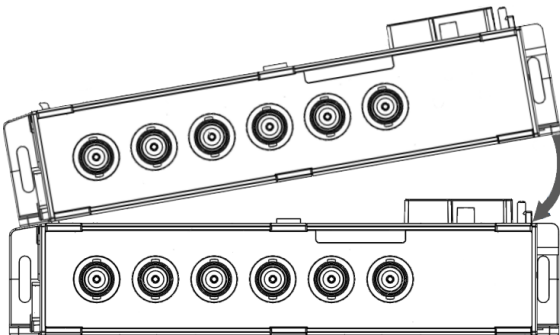

Fig. 4: locking latch

3. To finish mechanical connection, press on the imc Logo (2) on the locking latch. You will hear a click. Now the modules are mechanically locked and electrically connected.

Removing modules from the stack

1. Press the circle on the locking latch, see Fig. 4. You will hear a click.
2. Pull tongues, see Fig. 3 position (1) out of the grooves.

3.3.3 Using CANFT modules

imc ARGUSfit enables the integration of imc CANSASfit modules. These are clicked onto the left side of the ARGUSfit base unit. Additional modules can be connected by cable to the LEMO socket "CANSAS".

The channels of these modules are fully integrated into the imc STUDIO setup page as analogue channels. Further CANSASfit modules connected via a CAN FD module (interface) are integrated via the CAN editor and appear in the channel list as fieldbus channels.

- All CANFT modules clicked onto the ARGFT base unit use a CAN node with 500 kBaud (node 1).
- All CANFT modules connected to the ARGFT base unit via cable use a separate node with 500 kBaud (node 2). Both CAN nodes support imc CANSASfit (CANFT) modules only.
As long as the base unit is connected to a DC supply voltage, the CANFT modules are permanently supplied via the CANSAS socket regardless of the operating state (on/off) of the base unit.
- Blocks of up to 8 CANFT modules can be connected together if the power and the maximum current of the power supply allow this.



Note

First use of CANSASfit modules on the ARGUS

It must be ensured that the CANSASfit modules are operated with [imc CANSAS Software Version 2.3 R1](#) or higher before use on the imc ARGUSfit.

To do this, the module must be updated with the CANSAS software via a USB-CAN interface (e.g. KVASER) or an imc CRONOS/BUSDAQ device.

- This procedure is the minimum requirement for connecting these CANSASfit modules to an ARGUSfit device for the first time. When connected to the ARGUS, the CANSASfit module is updated with the appropriate firmware by imc STUDIO.

3.3.3.1 CAN Termination

CANSASfit modules must be terminated with a terminating resistor: ACC/CANFT-TERMI plug.

- With the CANSASfit modules **clicked on**, the terminator on the **outermost CANSASfit** is plugged into one of the two CAN/Power sockets.
- CANSASfit modules that are connected **by cable** to the CANSAS socket of the ARGUS Base must be terminated at the **first module** of the furthest module block.
- The terminator must be plugged in before the ARGUS system is switched on.

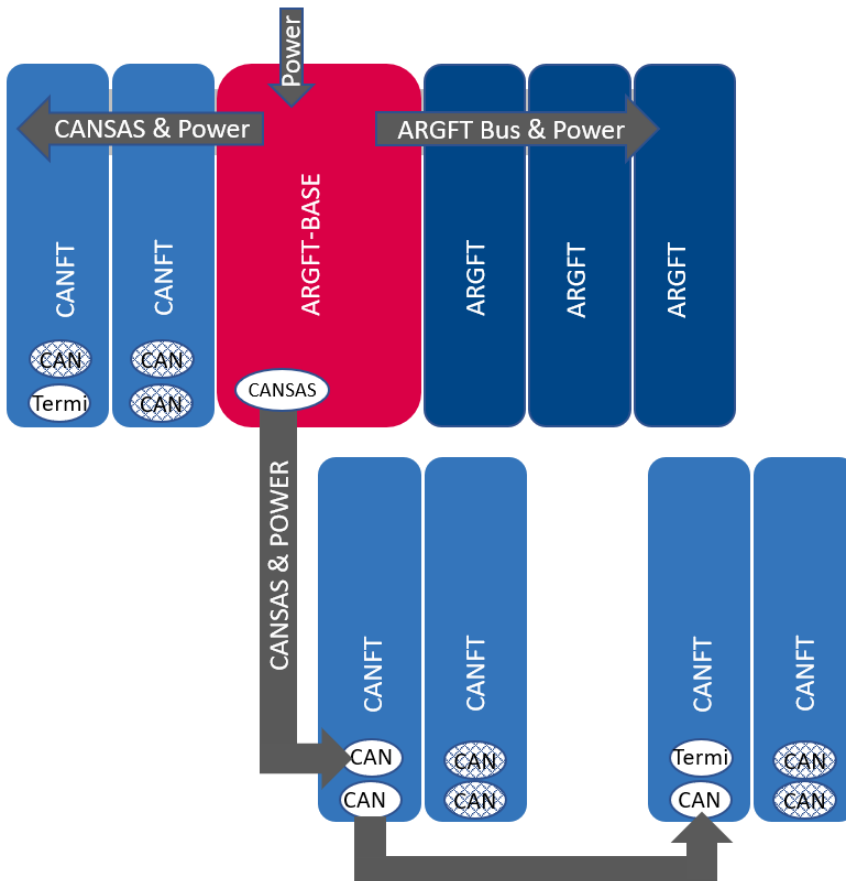

Fig. 5: CAN termination

Reference

[imc CANSAS manual](#)

See also chapter "CAN termination with CANFT" in the imc CANSAS manual.

3.3.4 Power supply

An imc ARGUSfit system is operated with a DC supply voltage that is supplied via an ARGFT module with a socket ("POWER") compatible with LEMO.EGE.0B.302. This can be an ARGFT-BASE or an ARGFT-FIBER-CONVERTER, for example. Power is supplied to the rest of the system via the internal supply network (power backbone) of the electrical click connections between the modules.

With regard to EN 61326-1 and EN 61010-1, the DC supply inputs are not specified for connection to a DC mains supply. This restriction does not apply if the power is supplied via ARGFT/UPS-xx.

The permissible supply voltage range is 10 to 50 V DC (ultra-wide range). For the AC/DC adaptor (power supply) supplied with the base unit, the specified AC voltage range on the input side is 110 V.. 240 V 50/60 Hz.

Note

Note that the operating temperature of the power supply adaptor is designed for 0 °C to 40 °C. This also applies if your unit should be suitable for an extended temperature range.

Direct connection to a DC supply source, such as a vehicle battery, is possible. Please note when connecting:

- Grounding of the imc ARGUSfit system must be provided. If the supply voltage source has a ground reference (ground connection to the -PWR terminal, then the device is automatically grounded via the -PWR terminal. The supplied power adaptor is prepared in this way, by providing a connection between -PWR and ARGUS housing inside the AC/DC adaptors's LEMO power plug (male). Otherwise the -PWR supply input of the device is not galvanically connected to ARGUS housing.
- The supply line must be of low impedance via a cable with a sufficient cross-section. Any EMI filters in the supply circuit should not contain series inductances greater than 1 mH. Otherwise, an additional parallel capacitor is necessary.

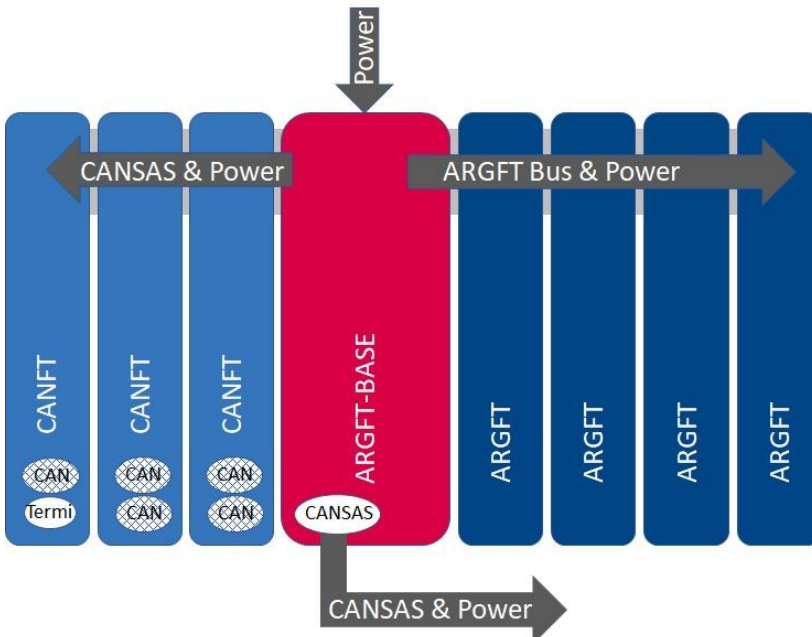

Fig. 6: Power supply via ARGFT base unit



= These CAN sockets cannot be used to connect further modules via cable.

References

Technical details concerning ARGFT power supply, see [chapter "Technical Specs"](#)⁸¹ and you can find the pin configuration in [chapter "Power"](#)¹⁰⁷

3.3.5 Fiber Converter

The Fiber Converter is a clickable module for the modular imc ARGUSfit system. It allows decentralized distributed system topologies.

The module converts the internal high-speed ARGUS system bus, which connects the ARGUS measurement amplifiers and interface modules via the click connector, to a fiber-optic data link in the sense of a media converter. Thus, the click connection can be extended to a spatially distributed arrangement of the entire ARGUS system by a pair of converters (base/remote satellite) and a fiber optic cable.

The Satellite block uses a joint power supply that is fed into the remote fiber converter module.

Fiber converter application

One fiber converter each is clicked onto both sides of the remote fiber connection. There must be at least one ARGFT module between two converters. A star-shaped arrangement is not permitted. The converters have a uniform design and recognize their function (in/out) automatically:

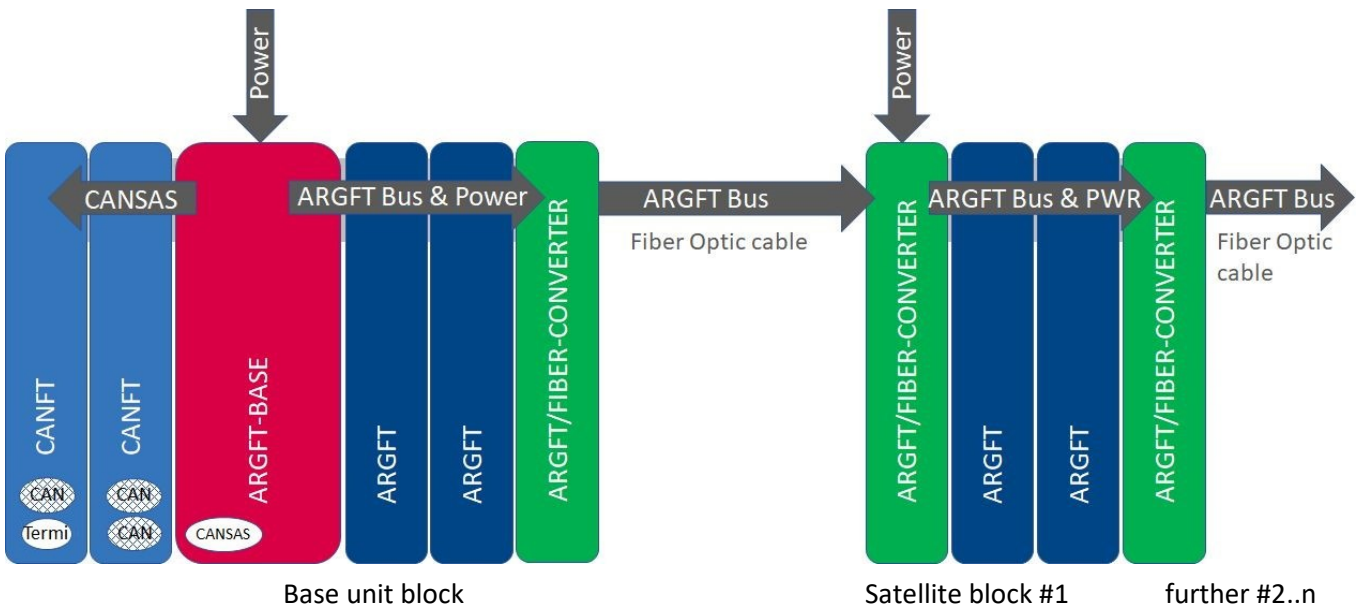

Fig. 7: Fiber converter application

The voltage supply of the base block is realized via the supply socket of the base unit. The power supply of the Satellite block (ARGFT Satellite block #1) and possibly further Satellite blocks #2..n is realized via the supply socket of the fiber converters clicked onto these Satellite blocks. For this purpose, a DC supply voltage or an AC/DC adaptor must be connected to the LEMO.0B (2-pin) "POWER" socket.

If the remote fiber converter detects no signal activity via the connected fiber cable, it deactivates the power supply of the clicked modules and enters in sleep mode with reduced power consumption. If signal activity is detected, the power supply for the clicked modules is activated. Thus, switching off the base unit always leads to switching off the Satellite blocks as well, and the slave fiber converters are put into sleep mode.

Reference

Technical specs for the Fiber Converter, see chapter ["Technical Specs"](#)¹⁰¹.

LED functionalities of the Fiber Converter, see section ["Status- & Power LED"](#)¹⁰².

3.3.6 UPS-NiMH

The UPS module is used to bridge short-term voltage failures that typically occur in vehicle electrical systems. The module is equipped with NiMH rechargeable batteries. These have sufficient capacity for multiple such events, each lasting a maximum of 30 seconds. If a single power failure exceeds the duration of 30 seconds, a self-shutdown of the system is triggered.

To supply the base unit or the fiber converter with power, a connecting cable (power cable) must be connected between the "POWER OUT" socket on the UPS module and the "POWER" socket on the base unit or fiber converter.

For switching the base unit on and off by the UPS module, a connection cable (control cable) is required between the "REMOTE OUT" socket and the "REMOTE" socket on the base unit. Once this connection has been made, only the on/off button on the UPS module may be used.

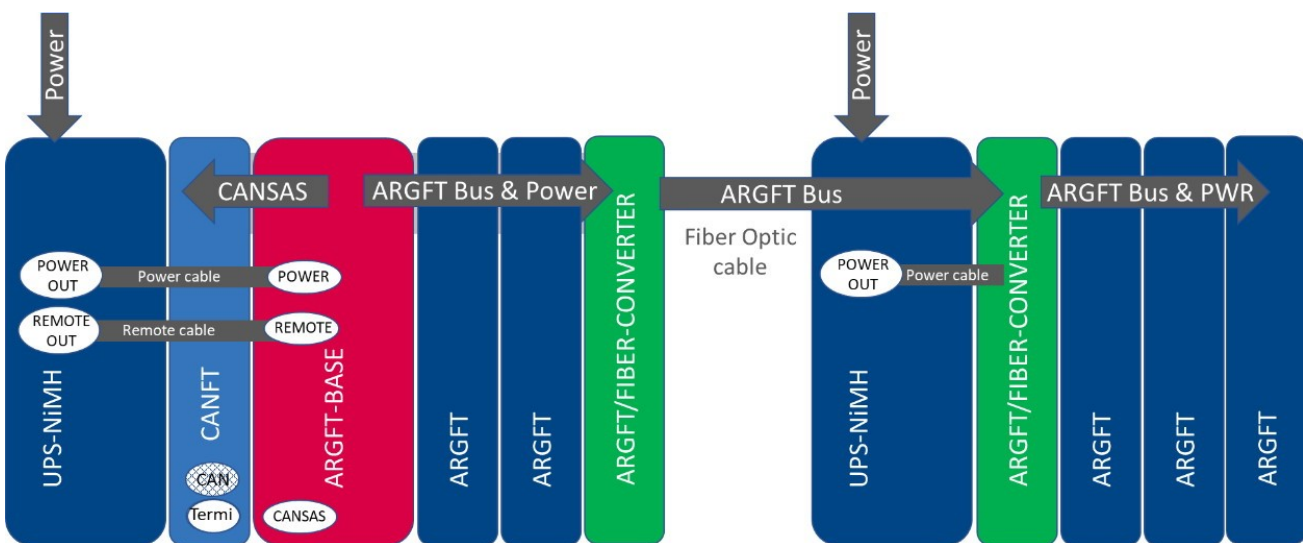

Fig. 8: ARGFT/UPS-NiMH with ARGFT/FIBER-CONVERTER

Powering on/off

The UPS module switches on when an external supply is applied via the "POWER IN" socket and

- the module's pushbutton is pressed.
- a pushbutton connected to the "REMOTE" socket is pressed.
- a switch connected to the "REMOTE" socket is closed.

A base unit connected to the UPS module receives a shutdown command via the plugged "**REMOTE**" **accessory cable** during operation or the UPS module switches off without a base unit connected when

- the UPS module's own button is pressed.
- a button connected to the UPS module's own remote socket is pressed.
- a switch connected to the UPS module's own remote socket is opened.
- *if* an overload case occurs (for details see [section "Output power"](#)^[23] and [section "Output-side overcurrent protection"](#)^[24]).
- *if* the UPS buffer duration has expired or the battery is completely discharged in battery mode.

If the UPS module does not respond to all attempts to switch it off, it can be switched off by pressing the module's button for at least 4 seconds. This prevents damage to the batteries due to deep discharge.

Remote socket

The UPS module has a "REMOTE" socket for switching the UPS module on and off and a "REMOTE OUT" socket for switching a base unit on and off.

The [assignment of the "REMOTE" socket](#)^[107] is identical to the assignment of other imc UPS modules (e.g. imc CRFX/HANDLE-xxx). A static switch (between pin 1 and pin 2) or a push button (between pin 3 and pin 4) can be connected for switching on and off.

A jumper between GND (pin 1/3/5) and **-MUTE (pin 6)** can be used to mute the **internal buzzer** of the UPS module for buffer operation.

In order for the UPS module to switch the base unit on and off, the corresponding **"REMOTE" accessory cable** must be connected between "REMOTE OUT" and the "REMOTE" socket on the base unit.

Output voltage for connecting the base unit and additional measuring modules.

The UPS module passes the external supply voltage directly to the output. In buffer mode, the internal battery voltage is regulated to approx. 12 V and applied to the output. The UPS module provides three "POWER OUT" sockets connected in parallel, to which the output voltage for the connected devices is applied. The available output power of the module is divided between all three connections. The [assignment](#)^[107] is identical with the "POWER IN" socket. In order for the UPS module to supply the base unit, the corresponding **"Power" accessory cable** must be connected between "POWER OUT" and the "POWER" socket on the base unit:

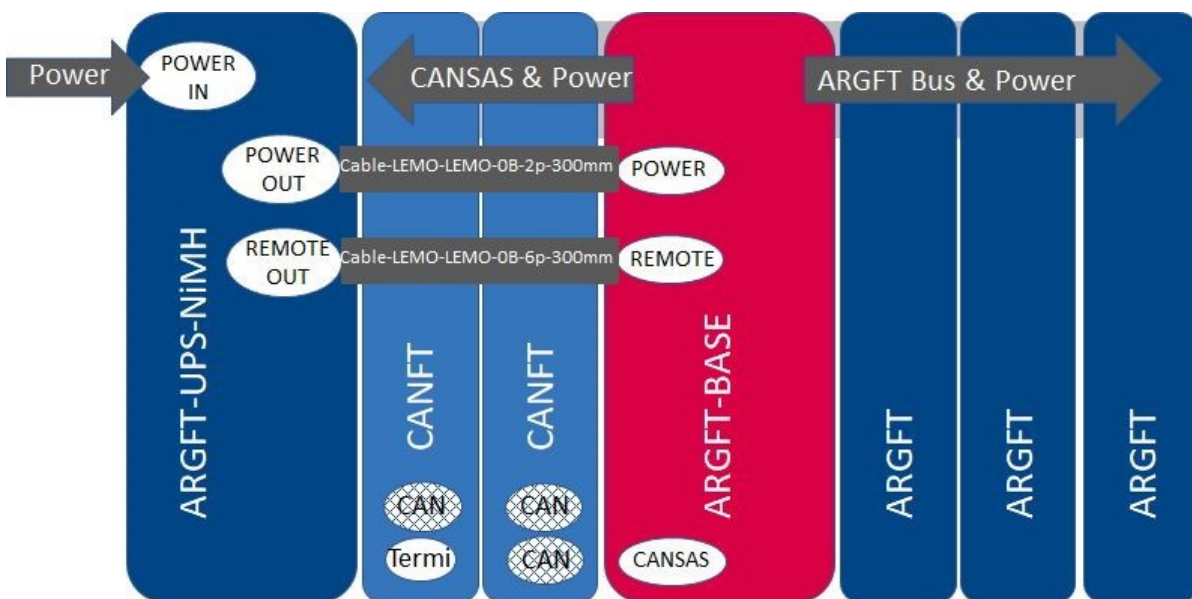

Fig. 9: Power supply via ARGFT/UPS-NiMH

Output power

The UPS module has an extended wide range input of 10..50 VDC. In this range an output power of 50 W is available. Below 10 VDC it is switched to battery operation. At low temperatures, the performance of the accumulators is limited, which means that the full output power may not be available in the buffer case, refer to the data sheet for thermal derating.

Output-side overcurrent protection

In order to protect against excessive output power requirements (too many modules) and error conditions, the UPS module has two independent current limiting circuits to protect the internal circuitry:

1. short-circuit protection (reaction time 10..30 ms)
2. static overload protection (reaction time approx. 1 s)

The **short-circuit protection** limits the output current to a resulting output power of typically approx. 70..85 W, depending on the output voltage. If this limit is exceeded, the output voltage is cut after approx. 10..30 ms and is only enabled again after approx. 4 seconds. If the short circuit condition has not been released, this procedure will repeat. During this "waiting" the "LIMIT" LED of the UPS module flashes red every second.

The **overload protection** measures the output power every second, evaluates it and will shut down the system in case of a static overload. If the permissible static output power of 50 W is exceeded, a shutdown process is initiated after 10 seconds (after 1 second in the buffer case). The "LIMIT" LED lights up yellow at an output power > 80 % and red at an output power > 95 % of the maximum permissible static output power.

UPS operation

The UPS module has a UPS with NiMH batteries. During normal operation with external supply the "POWER" LED is green, during battery operation the "POWER" LED is yellow. A device buzzer is active during UPS operation if pin 1/3/5 are not bridged with pin 6 of the "REMOTE" socket. The maximum buffer duration is fixed at 30 seconds. If the buffer time has expired, the base unit is shut down if it is connected. If only conditioners are connected, the UPS module is switched off immediately after the buffer time has elapsed.

A [4-segment LED display](#)²⁵ with battery symbol provides information about the charging status of the UPS. Whether the NiMH batteries are outside the temperature range for charging/discharging is indicated by the color of these LEDs.

Fuse

The UPS module is protected with a non-resettable 10 A fuse at the input.

If the UPS module only works in battery mode despite the supply voltage being present, this is an indication that an overload has triggered the fuse. Please contact the [imc Service](#)³² (E-Mail: service@imc-tm.de) to repair the module.





Nominal capacity

The nominal capacity quantifies the charge that can be stored in the battery at room temperature and, together with the battery voltage, gives the storable energy. In practice, this can differ significantly from the usable extractable energy, which depends on many parameters, such as the power (C-rate), the temperature or the previous history (age, number of cycles, lazy battery effect). This should be taken into account, especially for thermally demanding applications and high power requirements.

LED display

The UPS module is equipped with two multicolor LEDs and a 4-segment multicolor LED display, which provide information on various operating states:

Parameter	State
Power-LED green yellow red ("LIMIT" LED and 4 segment display off)	device is supplied via external supply voltage 10..50 VDC device is powered via internal battery an error has occurred. The following causes are possible: <ul style="list-style-type: none"> • Device has shut down, but may not switch off, e.g. due to closed remote switch. • internal error
"LIMIT"-LED green yellow red red flashing red and blue flashing alternately	actual output power at less than 80% of the permissible output power actual output power between 80% ... 95% of the permissible output power actual output power above 95% of the permissible output power; there is a risk of forced shutdown due to overload the short-circuit protection of the device has deactivated the output voltage for 4 seconds; the output voltage is then switched on again. The actual output power is greater than the reduced output power due to thermal derating. A sufficiently long buffer operation may not be available!

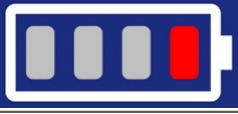
4 segment LED display	State
	Each segment represents 25% of the full battery capacity. When the battery is being charged, the rightmost of the illuminated state-of-charge segments flashes green at one-second intervals. In contrast, the warning signal when the battery is deep discharged (<10%) is characterized by the fact that only the left segment is lit and flashes at a faster interval.
	<div style="display: flex; align-items: center;">  Example </div> <p>The battery capacity is 50..74 % and the battery operates within its allowed temperature range for charging and discharging.</p>
	The battery temperature is too hot and is above the limit. Buffer operation is only possible for 10 seconds, charging is not possible.
	The battery temperature is too cold and is below the limit value. Buffer operation may only be possible for a short time and charging is not possible.
	Internal error of the UPS, buffer operation may not be possible.

3.3.7 Powering on

Press the on/off button  on the base unit for approximately 1 s.

After connecting the [UPS module](#) ²² to the base unit, only the on/off button on the UPS module needs to be pressed.

3.3.8 Powering off

The system is switched off by pressing the on/off button again (for approx. 1 s). 

The device does not switch off immediately when a measurement is in progress; if necessary, a measurement in progress is stopped and then measurement data on the microSD is completed, if internal storage is in use. This process takes a maximum of about 10 s. It is not necessary to press the power-on button continuously during this time. If no measurement is running, the switch-off process takes approx. 1 s.

Reference

If you use a **Fiber Converter** (ARGFT/FIBER-CONVERTER), please be sure to read [chapter "Fiber Converter"](#) ²¹.

3.3.9 Remote control of the base unit

As an alternative to the manual on/off button on the front of the base unit, an electrically remote-controllable contact on the remote socket can be used to switch the base unit and all modules connected to the base unit on and off.

Reference

Pin configuration of the LEMO socket, see [chapter "Remote"](#) ¹⁰⁷.

3.3.10 Storage media in the device

This section describes how to handle the storage media of the imc measurement devices and how to use them with imc STUDIO.

The storage media are exclusively for data acquisition with imc STUDIO.

Storage media with verified performance can be purchased as accessories from imc.



Note

Manufacturer and Age of the storage medium

- imc has no way to affect the quality of the removable storage media provided by the various manufacturers.
- Storage media which come with newly purchased devices have been inspected in the framework of quality assurance and have passed the relevant tests.
- We expressly declare that the use of removable storage media is at the user's own risk.
- imc and its resellers are only liable within the framework of the guarantee and only to the extent of providing a substitute.
- imc expressly declines any liability for any damages resulting from loss of data.

3.3.10.1 For devices of the firmware group B (imc DEVICEcore)

Swapping the storage medium

The microSD card may only be changed when the **device is switched off**.

3.3.10.1.1 Storage media

Storage media	Description
microSD	<ul style="list-style-type: none"> • Only microSD memory cards verified by imc should be used, as these have been specially qualified by us for high data rate of 5 MS/s. • The specified operating temperature range of the media is relevant.

3.3.10.1.2 Data transfer

The storage medium can be accessed **directly via Windows Explorer**. Alternatively, the storage medium can be inserted into a **card reader** on the PC (suitable for large amounts of data due to faster transfer).





Warnung

Do **not use force** to insert or remove the device storage medium.

Access via Windows Explorer

The menu item "*Data (Device)*" () causes the Windows-Explorer to start while indicating the device selected.

Ribbon	View
Extra > Data (Device) ()	Complete
Home > Data (Device) ()	Standard

Using this menu item, a separate Windows-Explorer is opened for each device, providing direct access to the internal memory.

For the purpose of accessing the tool, it is necessary to log in. The factory default settings are:

- User: "imc"
- Password: device serial number

Note

Manual entry

The device is called by reference to either its IP address or its internal name. The device's name is constructed as follows: "imcDev" + SerialNumber; e.g.

\\imcDev4120110

\\10.0.12.70

3.3.10.1.3 Memory cards - File system and formatting

Memory cards (microSD) with the file system FAT32 are supported. It is recommended that a memory card be [formatted](#) before use.

Note

Routine formatting protects the memory card

Routine formatting is recommended

Take every opportunity to format the storage medium. **Recommendation:** at least every **six months**.

In this way, any **damaged storage medium** can be detected and repaired if possible. A damaged file system may cause **data loss**. Or the **measurement system may fail to start** correctly.

In order to avoid data loss, any data still needed should first be saved!

Using a data storage medium in different devices

There are no known limitations. But it is recommended to always format the medium whenever transferring it in order to avoid data loss.

Notes

General restrictions applicable to file systems

Please observe the general restrictions regarding the respective file systems.

3.3.10.1.3.1 Formatting

Warning

Please back up the data first

Formatting causes all data on the storage medium to be deleted. Before performing the formatting, ensure that all data have been saved on a different storage medium.

The memory card (microSD) **can not be formatted in the device.**

For this purpose, please use an appropriate tool. Such a tool is provided on the installation medium for imc STUDIO in the folder "*Tools\RemoveableDriveFormatter*":

- "*rufus-4.1p.exe*"

This program can be used for the purpose of formatting the data volume.

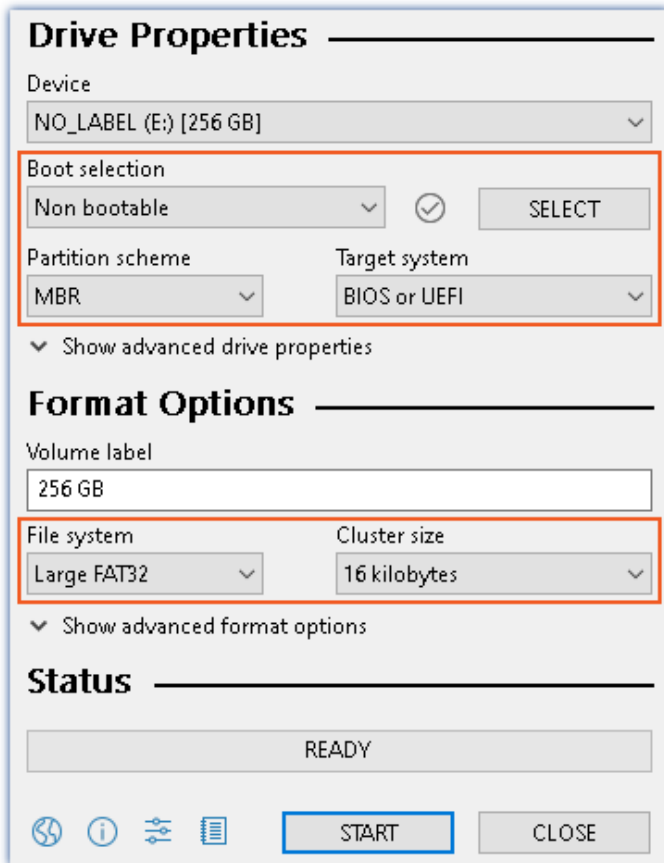

Settings required for formatting by means of Rufus 4.1

Make the **following settings** for the memory card:

- Boot selection: "*Not bootable*"
- Partition scheme: "*MBR*"
- File system: "*Large FAT32*"
- Cluster size: "*16 kilobytes*"

Note

Only **one(!)** partition may be created. Multiple partitions may cause the measuring device not to recognize the storage medium.

3.3.10.1.4 Known issues and limitations

Known issues and limitations	Description
File system becoming gradually slower	As the count of folders increases, so does the time required by the system to access the data. In consequence, the data saving procedure becomes slower and data loss becomes possible. For this reason, creating more than 1000 folders is to be avoided.
Errors in accessing the storage medium	<p>Errors can have the following causes, among others:</p> <ul style="list-style-type: none"> • The data rate is too high, the storage medium can't keep up and data overflow results. • The storage medium is full. <p>If the PC is connected to the measuring device, imc STUDIO documents the error with a message in the Logbook.</p>

3.3.11 LED display ARGFT-BASE

- ① STATUS LED for device state
- ② STORAGE LED for storage state of the local microSD



Fig. 10: ARGFT-BASE LEDs

① Status LED for device state

Module state	Status LED	
Power up		
Switch on	white	○
Starting	blue - flashing	⊖
Ready	blue	●
Measure		
Prepare	blue/green - flashing fast	⊙
Ready to measure	green	●
Run Trigger armed	green - flashing	⊖
Measurement completed	green	●
Power off		
Switch off	blue - flashing fast	⊙
Switched off	off	●
Miscellaneous		
Power Fail (stop recording, close files)	red	●
Firmware Update	magenta - flashing	⊖
Firmware required	magenta	●
Error	red - flashing fast	⊙

② STORAGE LED

Module state	STORAGE LED (microSD) - depending on fill level			
	no local storage	0..89%	90..99%	>99%
Power up				
Switch on	●	●	●	●
Starting	●	●	●	●
Ready	●	●	●	●
Measure				
Prepare	●	●	●	●
Ready to measure	●	● green	● yellow	● red
Run Trigger armed	●	⊖ green	⊖ yellow	⊖ red
Measurement completed	●	● green	● yellow	● red
Power off				
Switch off	●	●	●	●
Switched off	●	●	●	●
Miscellaneous				
Power Fail (stop recording, close files)	●	as previous state	as previous state	as previous state
Firmware Update	●	●	●	●
Firmware required	●	●	●	●
Error	●	⊛ rot	⊛ rot	⊛ rot

4 Maintenance and servicing

4.1 Maintenance and servicing

imc recommends performing a service check every 12 months. An imc service check includes system maintenance in accordance with the service interval plan as specified by the manufacturer and a complete function test (maintenance, inspection and revision).

Maintenance (*repair*) work may only be carried out by qualified personnel from imc Test & Measurement GmbH.

For service and maintenance work, please use the [service form](#) that you download from our website and fill out: <https://www.imc-tm.com/service>



Reference

Device certificates and calibration protocols

Detailed information on certificates, the specific contents, underlying standards (e.g. ISO 9001 / ISO 17025) and available media (pdf etc.) can be found on [our website](#), or you can contact us directly.

4.2 Cleaning

Disconnect imc ARGUSfit devices from all circuits before cleaning. Only [qualified personnel](#)¹¹ are permitted to clean the housing interior.

Do not use abrasive materials or solutions which are harmful to plastics. Use a dry cloth to clean the housing. If the housing is particularly dirty, use a cloth which has been slightly moistened in a cleaning solution and then carefully wrung out. To clean the slits use a small soft dry brush.

Do not allow liquids to enter the housing interior.

4.3 Storage

As a rule, the measurement device must be stored in a temperature range of -40°C to +85°C.

4.4 Transport

When transporting, always use the original packaging or a appropriate packaging which protects the imc ARGUSfit devices against shocks and impacts. If transport damages occur, please be sure to contact our tech support. Damage arising from transporting is not covered in the manufacturer's guarantee. Possible damage due to condensation can be limited by wrapping the device in plastic sheeting.



Reference

imc energy sources (batteries)

imc ARGUSfit devices will have a ["battery label"](#)¹⁰ on the nameplate for integrated energy sources.

5 Start of operation Software / Firmware

5.1 Installation - Software

The associated measurement engineering software imc STUDIO, the configuration and operating interface for all imc instruments, provides the devices with exceedingly versatile functionality. It achieves comprehensive total solutions for everything from laboratory tests through mobile data logger application all the way to complete industrial test stations.

Use of the software requires a license, subject to the purchase order and configuration (see e.g. imc STUDIO manual product configuration / license).

In order to be able to install or uninstall imc STUDIO products, you must be registered with a user account possessing administrator rights to the PC. This applies to the overwhelming majority of all installations of Windows. However, if you are only logged on to your PC without administrator rights, log off and log back on with an administrator user account. If you do not possess an administrator user account, you will need the support of your system administrator or IT department.

You will find a detailed description to the installation of the software in the adequate manual or getting started.

5.1.1 System requirements

The minimum requirements of the PC, the recommended configuration for the PC, the supported operating system are mentioned in the data sheets and the imc STUDIO manual.

5.2 Connect the device

There are multiple ways to **connect the imc measurement devices with the PC**. In most cases, the **connection via LAN** (local area network, Ethernet) is implemented. See section "[Connecting via LAN in three steps](#)"³⁴ for the **quickest way to connect** PC and measurement device.

But there are also other connection types:

- WLAN
- LTE, 4G, etc. (via appropriate routers)

These are described in a separate chapter in the software manual: "*Special options for connecting to the device*".

The devices use the **TCP/IP protocol** exclusively. With this protocol, some settings and adaptations for your local network may be necessary. For this purpose, the support of your network administrator may be necessary.

Recommended network configuration

The latest and high-performance network technologies should be used to achieve the maximum transfer bandwidth. This means especially 1000BASE-T (GBit Ethernet). GBit Ethernet network devices (switches) are downward compatible, so that imc devices that only support 100 MBit Fast Ethernet can also be operated on them.

The cable length between the switch and a PC or a device should be less 100 m. Use a shielded cable. If the length of 100 m is exceeded, then you have to insert another switch.

If the system is being integrated into an existing network, you must ensure that the minimum data rate can be guaranteed. Under some circumstances, this may require using switches to subdivide the network into separate segments in order to govern the data traffic in a targeted way and thus optimize the data rate.

In very demanding applications, you might consider grouping multiple GBit Ethernet devices via even higher-performance sections lines of the network (e.g. via 5 GBit Ethernet) and to connect these groups to NAS-components, for instance, via these lines.

When such imc devices are included which use network-based PTP-synchronization (e.g. CRXT or CRFX-2000GP), then it is necessary to use network switches which fully support this protocol on the hardware side. Appropriate network components are also available as imc accessories (e.g. CRFX/NET-SWITCH-5) and are then electrically and mechanically fully compatible with the imc systems.

5.3 Connecting via LAN in three steps

The most common case is described below: the PC and the device are connected via cable or network switch. The device's IP address must be set in the PC's address range. Subsequently, the device can be connected with the PC. If a connection has ever been established previously, the software recognizes the device's hardware configuration. In that case, experiment configurations can be prepared without any connection to the device.

Step 1: Connecting the measurement device

To connect via LAN there are two options:

1. The measurement device is connected to an **existing network**, e.g. via network switch. Only with a switch is it possible to run multiple devices.
2. The measurement device is connected directly to a network adapter on the PC (**point-to-point**).

In a LAN, the first case is typically implemented. Modern PCs and network switches are usually equipped with Auto-MDI(X) automatic crossover recognition, so that it is not necessary to distinguish between crossed and uncrossed connection cables. Thus both cable types can be used.

Step 2: IP-configuration

Start imc STUDIO. Click the "Device interfaces" button () to open the dialog for configuring the IP address of the device.

Ribbon	View
Setup-Configuration > Device interfaces ()	Complete

If this **button** is **not present** in the view, it is also possible to open the dialog after a device search if it failed to find any new devices. Subsequently, a prompt appears asking whether to search for devices with an inappropriately configured network interface. Close this message box by clicking "Yes".

Once the dialog starts, the system automatically searches for all devices in the network. In the tree diagram, all available devices are indicated. If the device appears among the group "Currently not reachable" ①, it is necessary to modify the device's LAN-settings. If the device appears among the group "Ready for measurement" ②, you can leave the settings as they are or review them.

Select the device for making modifications ③.

If there is any IP-conflict, devices affected will not be listed.

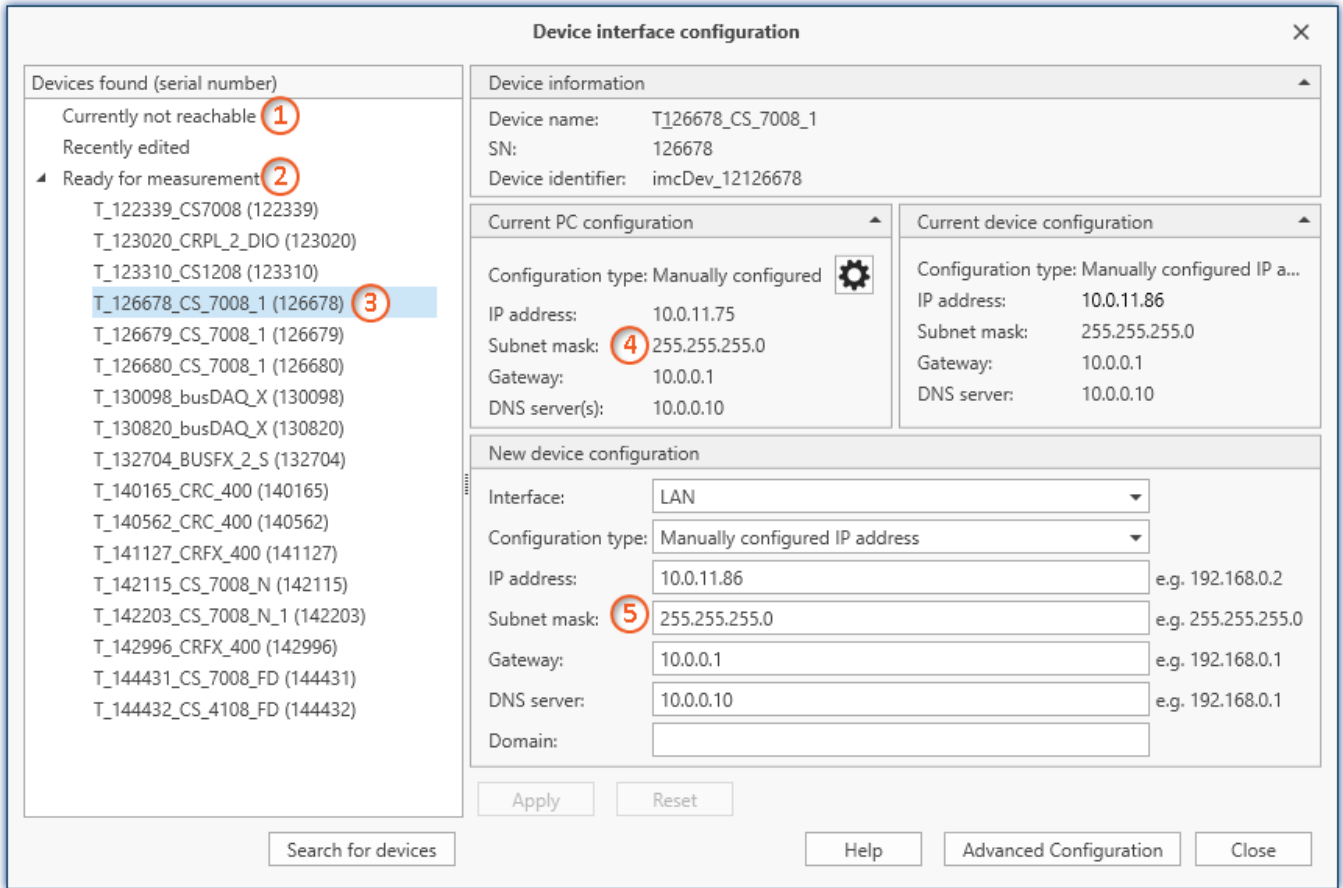

Display of measurement devices found and of the IP address

Set the **IP address manually** if you are not using DHCP. The device's IP address ⑤ must match with the PC's address ④. To conform to the network mask, only the device portion may be different (see example).

Example

In the example shown, the fixed IP 10.0.11.75 with subnet mask 255.255.255.0 is selected for the PC. For measurement devices, any numbers would be suitable which begin with 10.0.11. and then do not contain 0, 75, or 255. The 0 and the 255 should not be used, if possible, due to their special significance. The 75 is the computer's number.

Example for IP settings	PC	Device
IP address	10 . 0 . 11 . 75	10 . 0 . 11 . 86
Network mask	255 . 255 . 255 . 0	255 . 255 . 255 . 0



If the configuration type: "DHCP" is used, **the IP address is obtained automatically** from the DHCP-server. If it is **impossible to obtain any setting values** via DHCP, the **alternative values are used**. These could lead to errors in the connection (different networks, same IP addresses, etc.).

If there is a **direct connection** between the device and the PC by a cable, then **DHCP should not be used**.

In order to apply the changes, click on the button "Apply". Wait for the device to restart and then close the dialog.

Step 3: Integrating a device into an experiment

Now you are ready to add the device to the imc STUDIO experiment. If your device is unknown to the system, first perform the "device search".

Ribbon	View
Home > Search for devices ()	all
Setup-Control > Search for devices ()	Complete

Select the desired device: Once you click in the checkbox "Selected" for the desired device, it is ready to use in the experiment.

Selected	Device name	SN	Device specification
<input checked="" type="checkbox"/>	T_124835_C1_1_LEMO_ET	124835	imc C1-1 LEMO
<input type="checkbox"/>	T_130039_busDAQ_X	130039	busDAQ-X
<input type="checkbox"/>	T_130311_SPARTAN_U32_CAN	130311	imc SPARTAN

You can also select multiple devices for your experiment.

Now the device is "known". After the next program start it is available for selection. For further information, see the documentation on the component "Setup".

5.4 Firmware update

Every software version comes with matching firmware for the hardware. The software only works with devices having the right firmware.

Once the program connects up with the unit, the device's firmware is checked. If the software version doesn't match the device's firmware version, you are asked if you want to perform a firmware-update.

Note

The firmware update is only required if the software was obtained as an update. If you obtained your hardware equipment together with the software, no firmware update is necessary.



Warning

Do not interrupt the firmware update!

Be absolutely certain to observe the following:

1. Under no circumstances should the device or its power supply be deactivated during the firmware update!
2. The network connection may not be interrupted. Use a cable connection, not WLAN!

Upon the connection/preparation, the versions are compared. If they do not match, the next dialog notifies you about this, and indicates both which version is being used and which version is required.

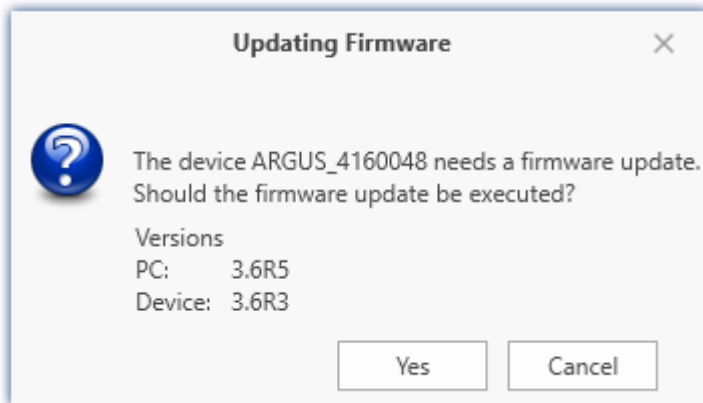

When you click "Yes", the firmware update starts. The duration of the update depends on the number of amplifiers (can last up to several minutes). You will be informed on the progress.

If the firmware update was successful, the dialog will close automatically after a few seconds. Subsequently the device can be used with the device software.



What to do in case of an error occurring in a firmware update?

Answer: When a firmware update fails to run correctly, the last active firmware is restored. The device remains operational by means of the previous installed firmware. Repeat the procedure, and if the repeat procedure also fails, please contact our tech support.

What is an optional update?

Answer: In some cases, a firmware update is not mandatory. In such cases, the update is available to you as "optional". However, we still recommend performing the update, since every update not only implements improvements, but also fixes any bugs. Nevertheless, with the new version of imc STUDIO, you are able to work with the device running the old firmware edition, if you choose.

6 Properties

6.1 Device overview

Some of the capabilities discussed in this document only pertain to certain device models. The associated device groups are indicated at the respective locations. The groups are shown in the following table.

— not available ● standard ○ optional
 CRXT imc CRONOS-XT CRFX imc CRONOSflex CRC imc CRONOScompact

imc device	SPARTAN	BUSDAQ	BUSLOGflex	BUSDAQflex	SPARTAN-R	SPARTAN-N	CRSL-N	CRC-400	C1-N	C-SERIE-N	C1-FD	C-SERIE-FD	CRFX-400	CRFX-2000	CRC-2000G	CRC-400GP	CRFX-2000G	CRFX-2000GP	CRXT	EOS	ARGUSfit
Driver package	imc DEVICES																		imc DEVICEcore		
Firmware group	A																		B		
Device group	A4				A5					A6	A7				B10	B11					
SN ¹	13				14					16	19				4120	416					
TCP/IP Interface [MBit/s]	100				100					100	1000				1000	1000					
Sampl.Rate ² [kHz]	400				400					2000 / 400 ³	2000 / 400 ³	2000 / 400 ³	2000	2000	2000	4000	5000				
STUDIO Monitor supported	●				●					●	●				—	—					
Connections ⁴	4				4					4	4				—	—					
Signal processing in the device																					
Online FAMOS	○	○	—	○	○	●	●	●	●	●	—	—	—	—	—	—	—	—	—	—	●
Preprocessing original channel	●	—	—	—	●	●	●	●	—	—	●	●	—	—	—	—	—	—	—	—	—
Preprocessing monitor channel	●	—	—	—	●	●	●	●	—	—	●	●	—	—	—	—	—	—	—	—	●
Data Storage																					
CF	●				●					—	—				—	—					
Express Card	—				—					●	—				—	—					
CFast	—				—					—	●				—	—					
USB	—				—					●	●	●	●	●	—	—	—				
microSD	—				—					—	—				—	●					
Storage on network drive	●				●					●	●				—	—					
Internal hard disk	○	(○) ⁵	—	—	○	○	—	—	○	○	—	—	○	○	○				●	—	
Synchronization																					
DCF	●				●					●	●				—	—					
IRIG-B	—	—	●	●	●					●	●				●	●					
GPS	●	●	—	(●) ⁶	●					●	●				—	●					
NTP	—	—	●	●	●					●	●				●	●					
PTP	—				—					—	—	●	—	●	●	—	—				
Phase offset correction	—	—	●	●	●					●	●				●	●					

1 Extend serial number range by four digits (three for imc EOS)
 2 Max. aggregate sampling rate (see data sheet)
 3 2000 via EtherCAT else 400
 4 Number of imc STUDIO Monitor-connections or imc REMOTE (as of 14xxxx) connections
 5 not available for imc BUSDAQ-2
 6 not available for imc BUSDAQflex-2-S

6.2 Device description



Fig. 11: Photo of the front of the base unit

imc ARGUSfit – fast, compact and modular measurement systems

imc ARGUSfit is a compact modular system that allows the user to flexibly assemble fast data acquisition systems (DAQ). Both the base unit and the flexibly combinable measuring modules have independent housings which are connected by a "click" mechanism (no tools required) to form a DAQ system. This modularity includes not only measurement amplifiers but also interface modules such as for CAN bus.

imc ARGUSfit covers the entire frequency range of physical measurement applications with an aggregate sampling rate of up to 5 MS/s and channel rates of up to 500 kSample/s, depending on the module type. Various such measurement modules for common signals and sensors are available and more will be released in the future.

In addition, interface modules can be added to integrate common field and vehicle buses such as CAN FD into the data acquisition and to exchange measurement data via these communication standards.

The system achieves particular flexibility by extending modularity even to decentralized topologies. The internal ARGUS high-speed system bus can be converted to fiber optic cables by means of a media converter extension module in order to integrate spatially distributed module blocks.

imc ARGUSfit also provides complete integration of the imc CANSASfit module series for slower channels, e.g. for temperature measurement: while fast imc ARGUSfit modules are docked to the bottom (right side) of the imc ARGUS base (high-speed system bus), imc CANSASfit modules can be clicked onto the top (left side). Such CANSASfit modules (CANFT) are likewise internally connected with power and CAN bus and are fully supported and integrated by the software as a uniform system. Finally, CANFT modules can even be installed in distributed topologies and connected via CAN-cable to the CANSAS-Interface of the base unit, provided on a dedicated LEMO.0B terminal.

The resulting DAQ system is networked by Ethernet and configured via a connected PC. In measurement mode, the PC can then serve as a sink for recorded data (continuous "streaming").

In stand-alone operating mode, the PC is not even required and the measurement data can also be stored on removable microSD flash memory. Live measurement data can already be pre-processed or evaluated by onboard realtime analyses (imc Online FAMOS). This applies to stand-alone mode, too. Typical analysis functionalities and applications include limit value monitoring, min./max. statistics, digital filters, spectral analysis, order analysis, classification and much more.

Multiple DAQ systems of the imc ARGUSfit series as well as other imc data logger and measurement systems can be interconnected via Ethernet. This allows to operate very large and multi-channel setups in which different imc device series work together uniformly and fully synchronized. The Ethernet interface can then be used for communication and data exchange as well as for absolute time synchronization of the entire system (via NTP).

6.2.1 Mechanical dimensions

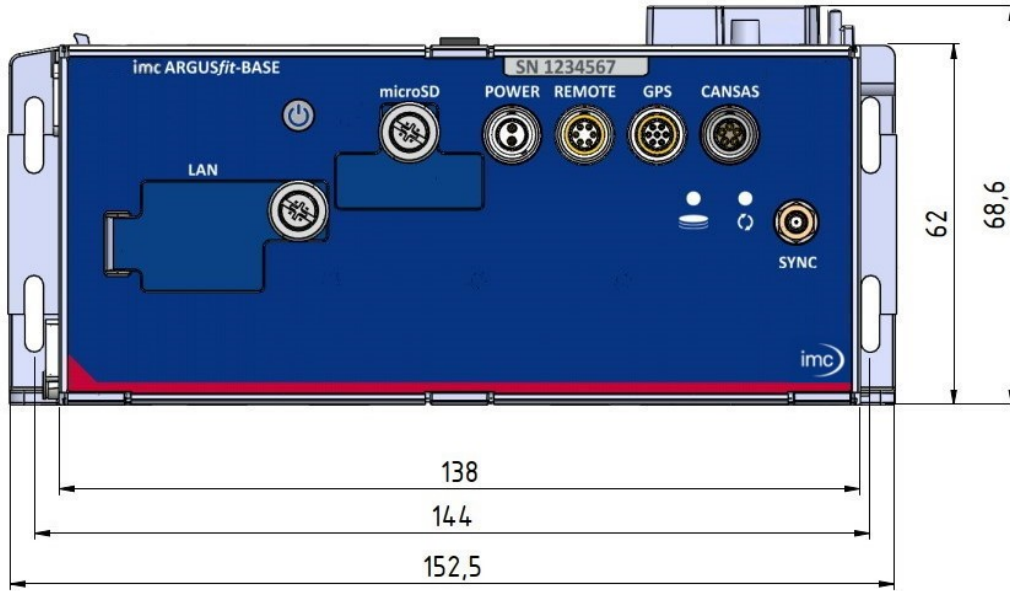

Fig. 12: Dimensions, extra wide XW housing: applies to base unit and UPS

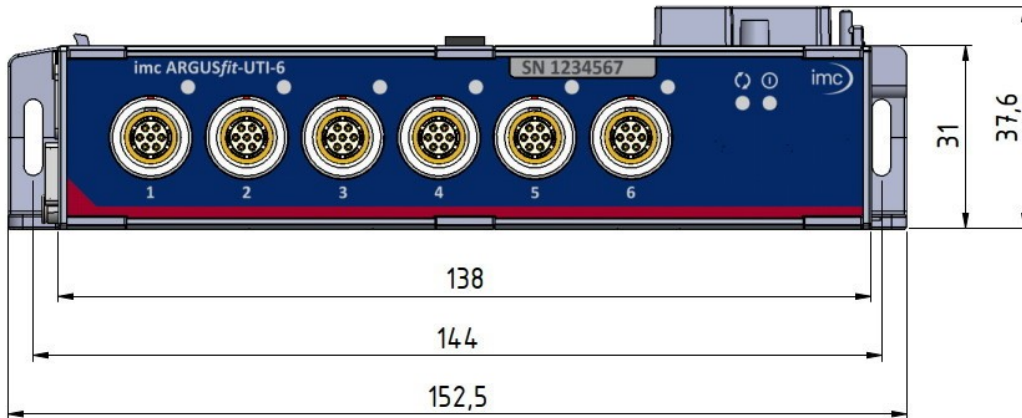
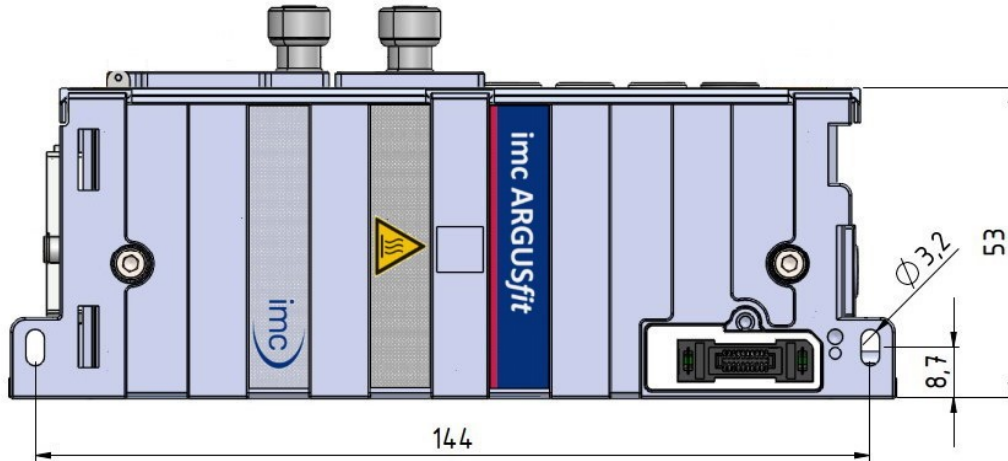
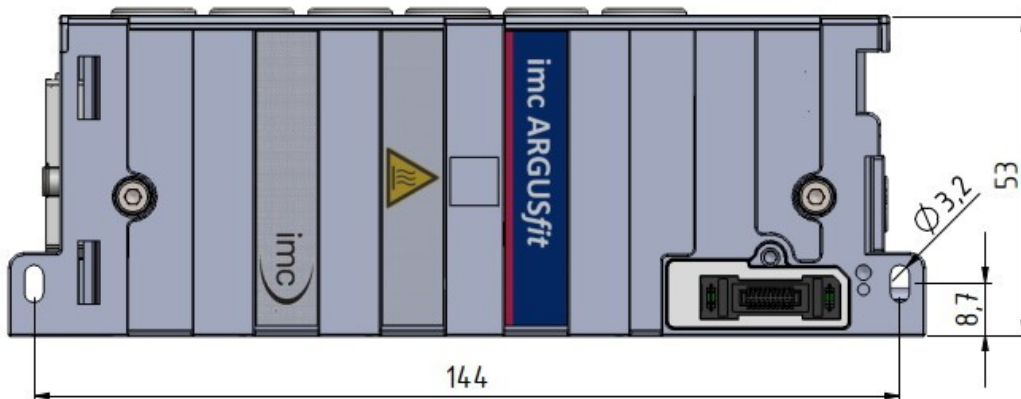

Fig. 13: Dimensions, narrow standard housing: applies to UTI-6, ICPU-6, Fiber-Converter, CAN FD Interface and the B-4

The following illustrations show ARGFT modules in the intended position of use (with the connections facing upwards).



extra wide XW housing



narrow standard housing

6.2.2 Included accessories

For an overview of the accessories supplied as standard, please refer to the data sheet of the imc ARGUSfit module supplied.

6.2.3 Optional accessories

For an overview of the available accessories, please refer to the data sheet of the imc ARGUSfit module supplied.

6.2.4 GPS

At the GPS socket it is possible to connect a GPS-receiver. This makes it possible to achieve absolute **synchronization to GPS time**. If the GPS-mouse has reception, the measurement system synchronizes itself automatically. **Synchronization with a NMEA source** is possible. The precondition for this is that the clock must return the GPRMC-string along with the one-second-interval clock signal.

All **GPS information** can be **evaluated** and subjected to **subsequent processing** by imc Online FAMOS.

GPS signals are **available as**: process vector variables and fieldbus channels.

GPS information	Description
pv.GPS.course	Course in °
pv.GPS.course_variation	Magnetic declination in °
pv.GPS.hdop	Dilution of precision for horizontal
pv.GPS.height	Height over sea level (over geoid) in meter
pv.GPS.height_geoidal	Height geoid minus height ellipsoid (WGS84) in meter
pv.GPS.latitude pv.GPS.longitude	Latitude and longitude in degree (Scaled with 1E-7)
pv.GPS.pdop	Dilution of precision for position
pv.GPS.quality	GPS quality indicator 0 Invalid position or position not available 1 GPS standard mode, fix valid 2 differential GPS, fix valid ...
pv.GPS.satellites	Number of used satellites.
pv.GPS.speed	Speed in km/h
pv.GPS.time.sec	The number of seconds since 01.01.1970 00:00 hours UTC. For this reason, it is no longer possible to assign the value to a Float-format channel without loss of data. This count of seconds can be transformed to absolute time under Windows and Linux. To do this, use the function below. <pre>MySeconds = CreateVChannelInt(Channel_001, pv.GPS.time.sec)</pre>
pv.GPS.vdop	Dilution of precision for vertical see e.g. www.iota-es.de/federspiel/gps_artikel.html (German)

 Note

Scaling of the latitude and longitude

pv.GPS.latitude and pv.GPS.longitude are **INT32 values, scaled with 1E-7**. They must be **treated as Integer channels**, otherwise the **precision is diminished**.

By means of imc Online FAMOS, you are able to generate virtual channels from them. However, due to the reversal of the scaling, precision is lost:

```
latitude = Channel_001*0+pv.GPS.latitude *1E-7
```

Recommendation: Use the corresponding fieldbus channel: "*GPS.latitude*" or "*GPS.longitude*". Here, no scaling is required, so that the precision is preserved.

Sampling rate

Due to system limitations, GPS channels for determining the fastest sampling rate in the system are not taken into account. For an working configuration, at least **one other channel** (fieldbus, digital or analog) must be sampled at either the **same** sampling rate as the GPS-channel, or a **faster** one.

GPS-Receiver

The **GARMIN GPS receivers** supplied by imc are set ready for operation and provide a 1 Hz or 5 Hz pulse, depending on the model.

The following conditions must be met in order to use other GPS receivers from imc devices:

- **RS232 port settings**
 - **Baud rate:** Possible values are 4800, 9600, 19200, 38400, 57600 or 115200
 - 8 bit, 1 stop bit, no flow control
- The following **NMEA strings** must be sent: **GPRMC, GPGGA, GPGSA**. The order of the strings must be adhered to.
Additional strings should be deactivated. If this is not possible, all other strings must be **before** the GPGSA string!
- The receiver must deliver a **1 Hz clock**.
- The rising edge of the clock must mark the second specified in the next GPRMC string.
- All three strings should be sent as soon as possible after the 1 Hz clock, so that there is sufficient time for processing between the last string and the next 1 Hz clock.

NMEA-Talker IDs

Supported NMEA-Talker IDs:

- GA: Galileo Positioning System
- GB: BeiDou (BDS) (China)
- GI: NavIC (IRNSS) (India)
- GL: GLONASS, according to IEIC 61162-1
- GN: Combination of multiple satellite systems (GNSS) (NMEA 1083)
- GP: Global Positioning System (GPS)
- GQ: QZSS regional GPS augmentation system (Japan)

[GPS LEMO pin configuration](#) 

6.2.5 Synchronization

Synchronization within a device

All measuring and extension modules synchronize automatically with the base unit via the ARGUS system bus and use a common time base.

Time grid

All measuring points are synchronized to a **time base of 1 second** regardless of their sampling rate. Channels with **sampling intervals greater than 1 second** also start at the next second of this time grid. For these channels, the time stamp can be shifted by one sample if they originate from different modules:

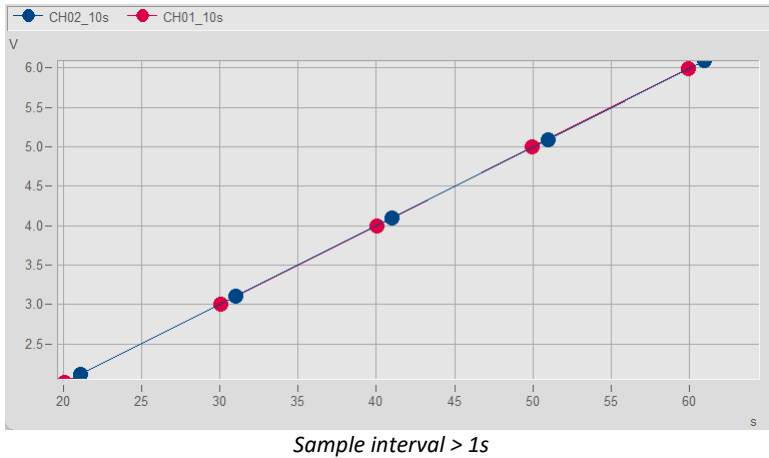

Note

Calculation in online/inline FAMOS

As can be seen in the image above, the measuring points are set with the correct time. If the channels are calculated with each other in Online-/Inline- FAMOS, however, the time stamp is not taken into account. The data is calculated in pairs, resulting in a phase of up to one sampling interval.

This effect can be avoided by recording the channels with a sampling rate ≥ 1 Sps/s and reducing the resulting sampling rate, e.g. with a mean value function (*Mean()*).

Synchronization with other devices

In order to synchronize the device to an absolute time reference and/or synchronize multiple imc devices (even of different types) use the SYNC terminal. That connector has to be connected with other imc devices (as of serial numbers higher than 14...) or a IRIG B signal generator.

Synchronization with GPS

The measuring device can be synchronized to absolute time using a [GPS receiver](#)⁴² connected to the GPS socket.

Reference

[Technical Specs](#)⁸⁵

In the imc STUDIO manual, you will find a description of the settings and all scenarios of the synchronization variants in the "Synchronization" chapter.

6.2.6 Filter settings

The primary purpose of signal filtering is to suppress unwanted spectral components, reduce the data rate and memory requirements and improve the signal-to-noise ratio SNR (by approx. 3 dB/octave or 10 dB/decade for AAF, Butterworth and Bessel) while reducing the bandwidth of passband.

6.2.6.1 Theoretical background

The filter setting is of particular importance in a sampling system. The **sampling theorem** (Nyquist, Shannon) states: The sampling frequency f_s must be more than twice as large as the largest signal frequency f_{max} (bandwidth of passband) of the analog signal that is to be digitized. The analog output signal can then be reconstructed from the digital image of the signal. If this condition is violated (undersampling), frequency components (shaded gray in Fig. 14) that were not contained in the original signal (aliasing error) will occur during reconstruction. They can no longer be fixed by post-filtering. Filtering should therefore be used to limit the bandwidth to less than $\frac{1}{2} \cdot f_s$. The corresponding filter is called an Anti-Aliasing Filter (AAF).

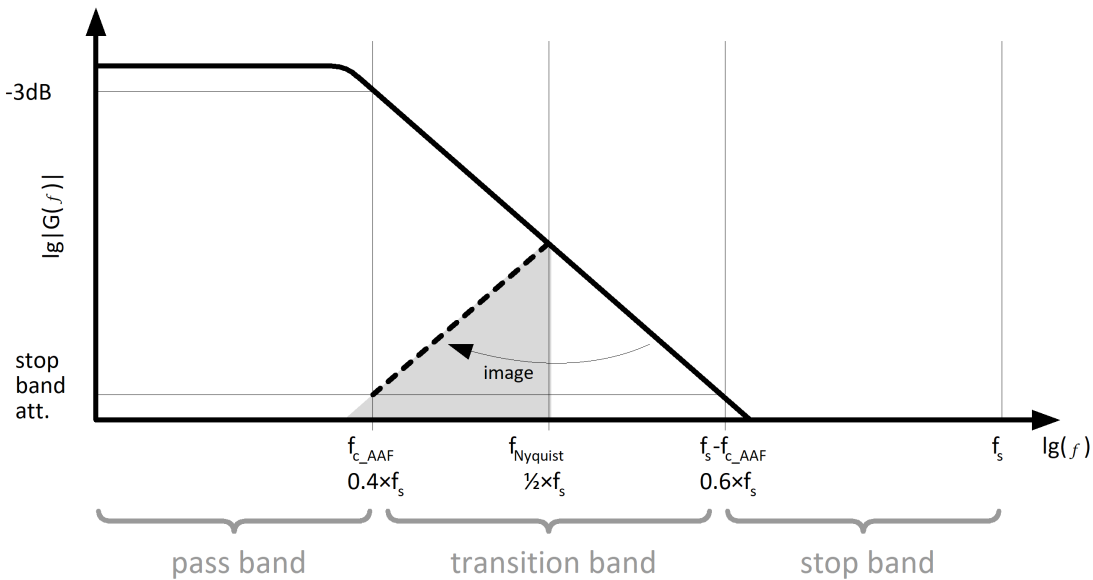

Fig. 14: Overview of the sampling theorem with Anti-Aliasing Filter (AAF) of the ARGUS series

6.2.6.2 General filter concept

The imc system uses a two-stage system architecture.

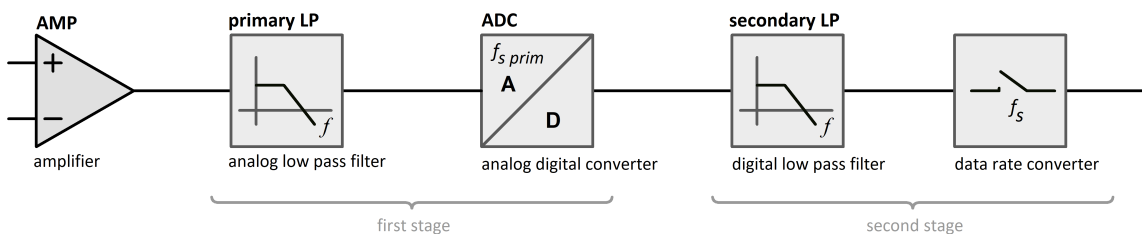

Fig. 15: signal processing chain of the ARGUS series

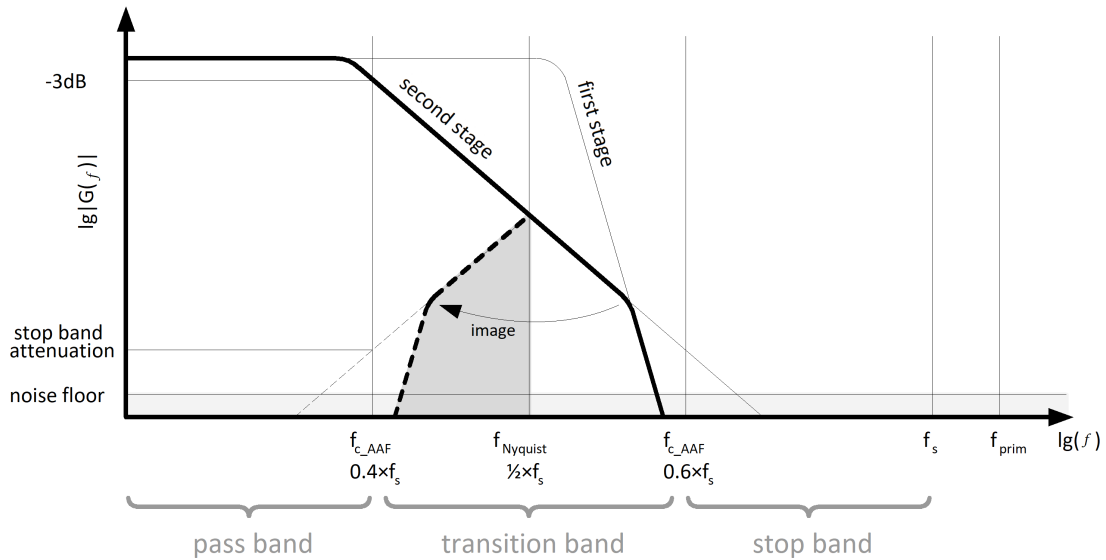

Fig. 16: Frequency response of the ARGUS series

In the first stage, the amplified analog signal is sampled at a usually fixed primary sampling rate $f_{s\text{ prim}}$. An analog low-pass filter matching to $f_{s\text{ prim}}$ avoids aliasing errors. The primary sampling frequency $f_{s\text{ prim}}$ depends on the channel type and is usually greater than or equal to the sampling rate f_s .

The second stage reduces the series of measured values to the desired data rate f_s , which can be selected in the settings interface. Since a second sampling takes place here, for which the sampling theorem also applies, the signal bandwidth should be limited using an adjustable digital low-pass filter. The filter options are described in the following sections. They can be subdivided according to filter type, filter characteristic and cut-off frequency. Options highlighted in Fig. 17 are available in the ARGUS product group.

filter type	filter characteristic
bypass	average filters
low pass	Bessel filters
high pass	Butterworth filters
band pass	elliptic filters (Cauer)
all pass	Chebyshev filters

Fig. 17: Filter options of the ARGUS series

In contrast to analog filters, the frequency response and the phase response of the adjustable digital filter is free of tolerances. Channels therefore have good synchronization with the same filter setting. If signals are calculated with each other, the results are precise over the entire pass band range. With digital filters, the maximum amplitude of the input signal must not exceed the measuring range. This also applies to signal components whose frequencies are to be reduced by the filter.

Application examples:

	AAF	Butterworth	Bessel	Average filter
Spectral analysis (bandwidth of passband)	⊕⊕	⊕	⊖	⊖
Control engineering (group delay)	⊖⊖	⊖	⊕⊕	⊕⊕
Status analysis (quasi static)	⊕	⊕	⊕⊕	⊖

The following figure 18 shows a comparison of the filter characteristics for low-pass filters with similar bandwidths using the example of the ARGFT/ICPU-6.

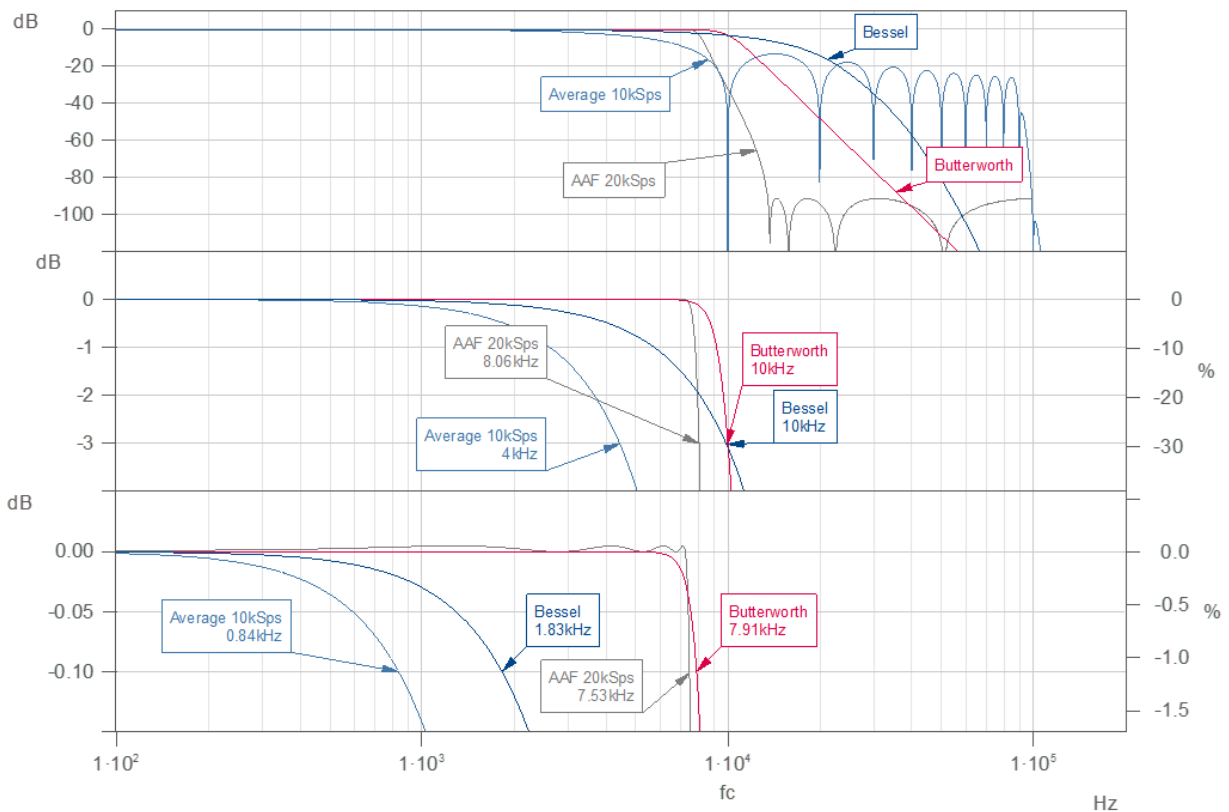

Fig. 18: Comparison of different filter characteristics for low-pass filters ($f_{s\ prim} = 200\ kSps$)

Fig. 19 compares the step responses of the different filter characteristics. For better clarity, the signals are shown in continuous time. In practice, the discrete-time measured values lie on these graphs, as shown for "AAF" as an example. Their position depends on the time difference between the input step and the sampling time.

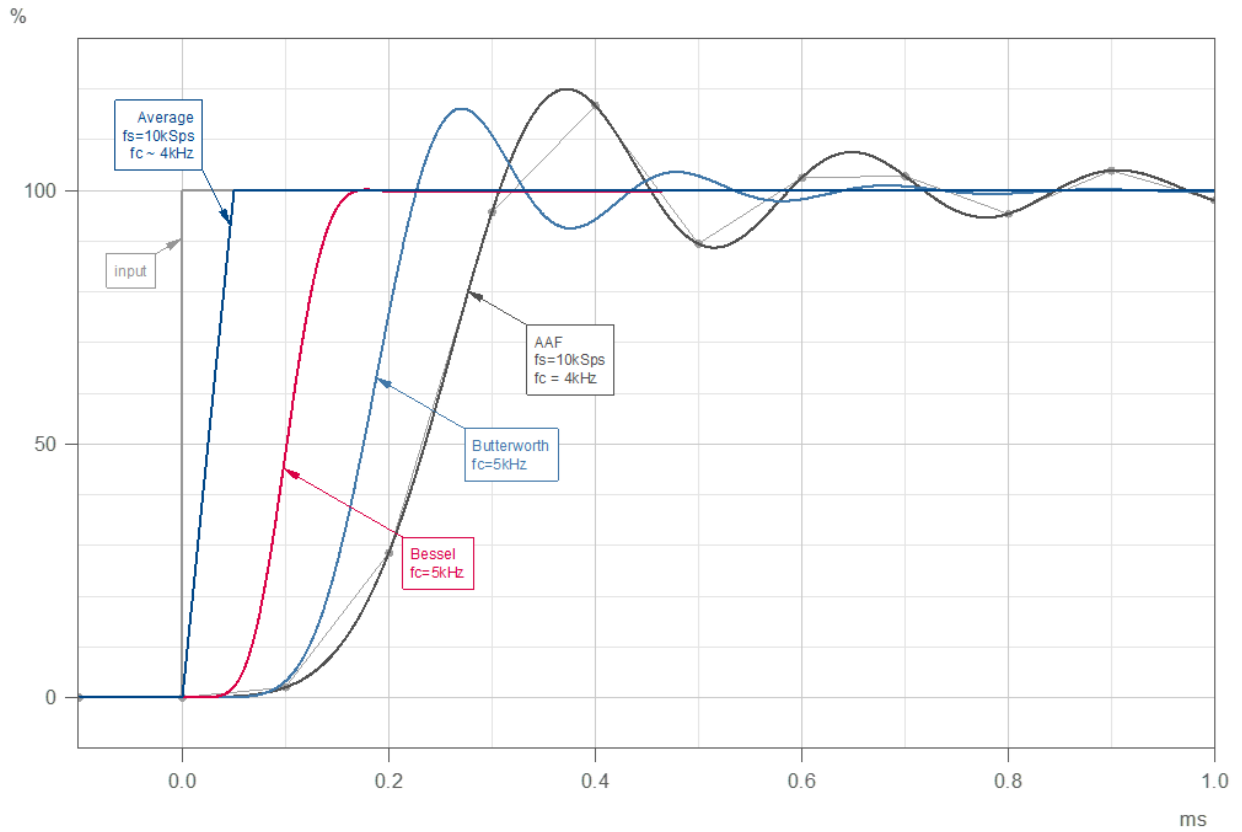

Fig. 19: Comparison of the step response of different filter characteristics

6.2.6.2.1 Filter setting: "Filter type: AAF"

The anti-aliasing filter is designed as an 8th order elliptical Cauer filter. Its transition band between the passband and the stopband is very narrow - the difference between Nyquist and cut-off frequency is very small. The filter characteristic of the Cauer filter has the widest bandwidth, but this is also accompanied by a strong and long-lasting transient response in the time domain.

With the "AAF" setting, the cut-off frequency f_c is automatically adjusted according to the selected sampling rate, and $f_{c_{AAF}} = 0.4 \cdot f_s$ applies with an attenuation of -3 dB. The Cauer filter has an attenuation of typically -86 dB in the stop band and a ripple of 0.005 dB (approx. 0.06%) in the pass band.

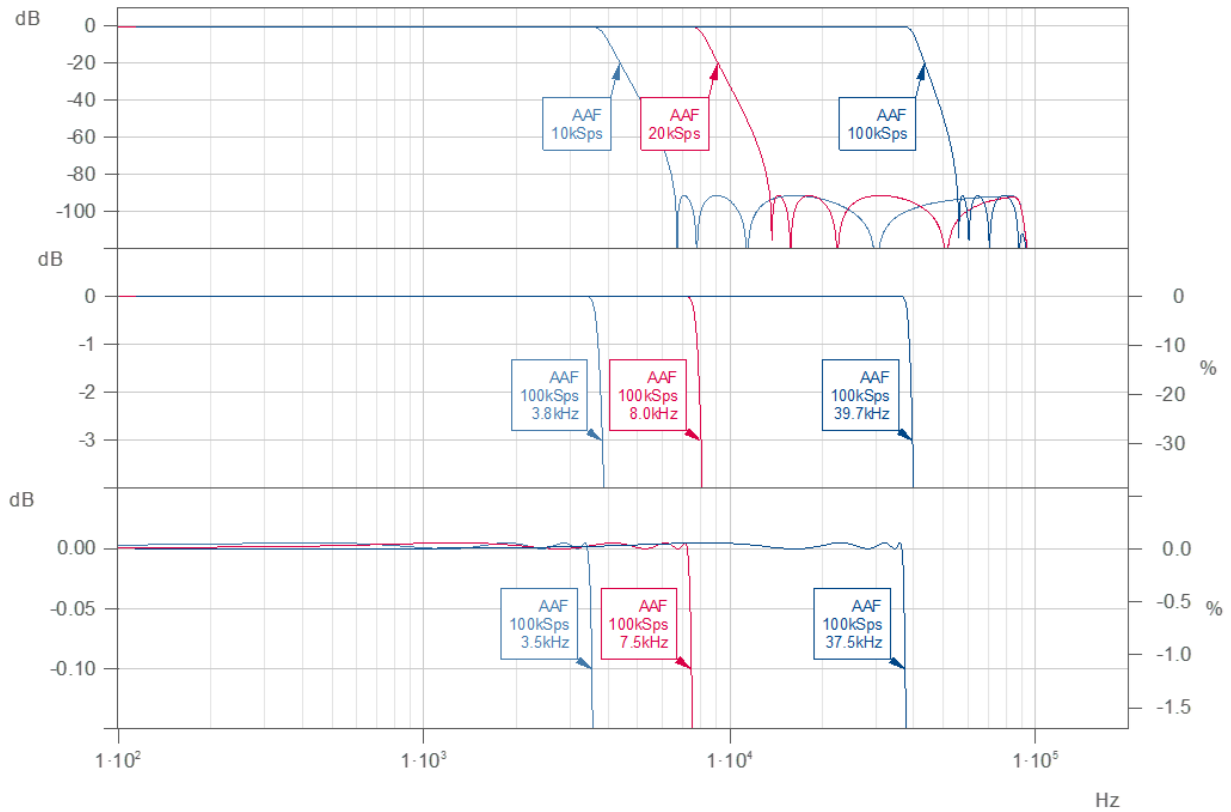

Fig. 20: "Filter type: AAF" (Cauer) for different cut-off frequencies ($f_s \text{ prim} = 200 \text{ kSps}$)

6.2.6.2.2 Filter setting: "Filter type: low pass"

Average filters

With average filtering, the arithmetic mean is formed over a number of N measured values and output at the selected sampling rate f_s . The number N results from the ratio of the primary sampling rate f_{s_prim} to the sampling rate f_s : $N = f_{s_prim} / f_s$. Due to the first filter stage, the frequency response is not periodic with the primary sampling rate f_{s_prim} , but is limited to $= f_{s_prim} / 2$.

Fig. 21 shows an example of the amplitude responses for higher sampling rates. For lower sampling frequencies, cut-off frequencies proportional to the sampling rate apply.

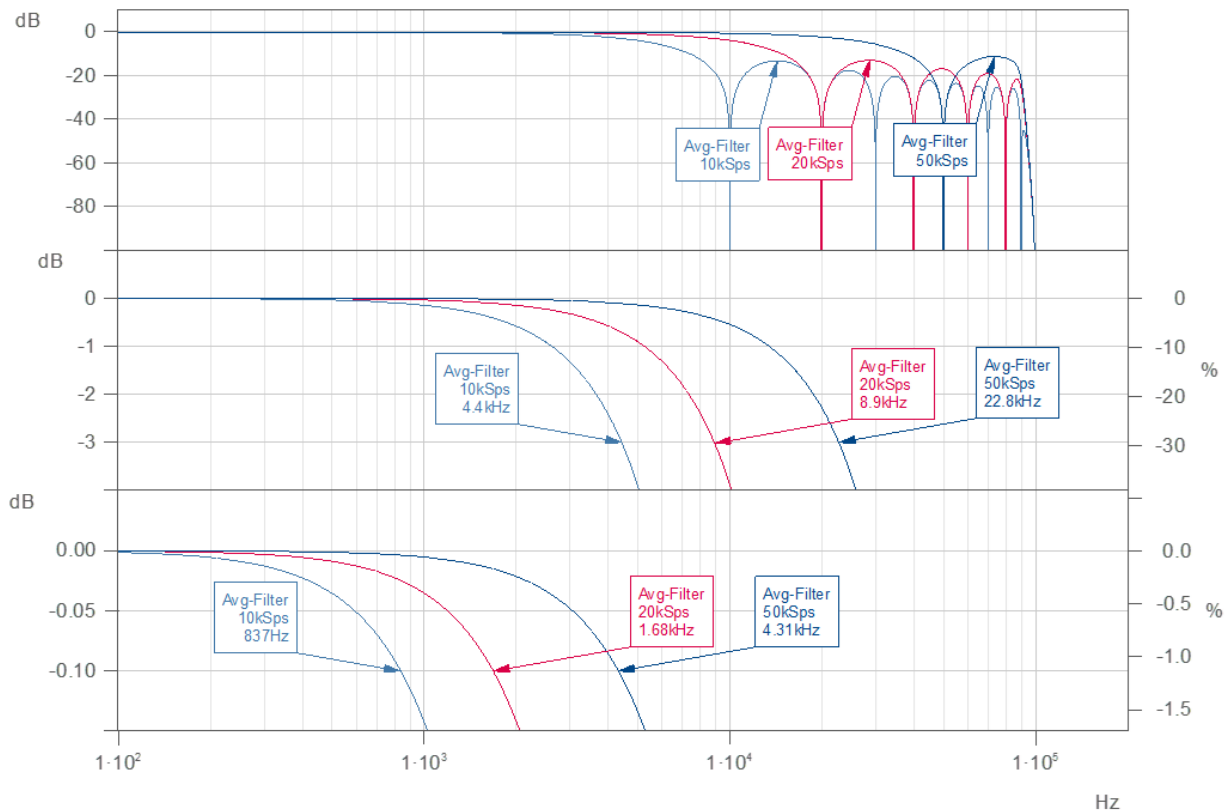

Fig. 21: "Filter type: Average filter" for different sampling rates ($f_{s_prim} = 200 \text{ kSps}$)

The average filter has a zero point in the frequency response at the set sampling rate. As there is only a low stopband attenuation above this point, some spectral signal components above the Nyquist frequency are reflected in the pass band. As a result, the signal-to-noise ratio is also worse than with other filter characteristics of the same bandwidth. An average filter is therefore less suitable for reducing the data rate. If possible, the "Bessel" or "Butterworth" characteristic should be used unless a low group delay is required.

Bessel

Bessel filters - also known as Bessel-Thomson filters - are optimized for a constant group delay t_{grp} in the pass band. They therefore have a good impulse response. The transition band of the frequency response is relatively wide, so the sampling rate should be about 5 times the cut-off frequency f_c . There is no ripple in the pass band. The step response shows only a slight overshoot of approx. 0.3%.

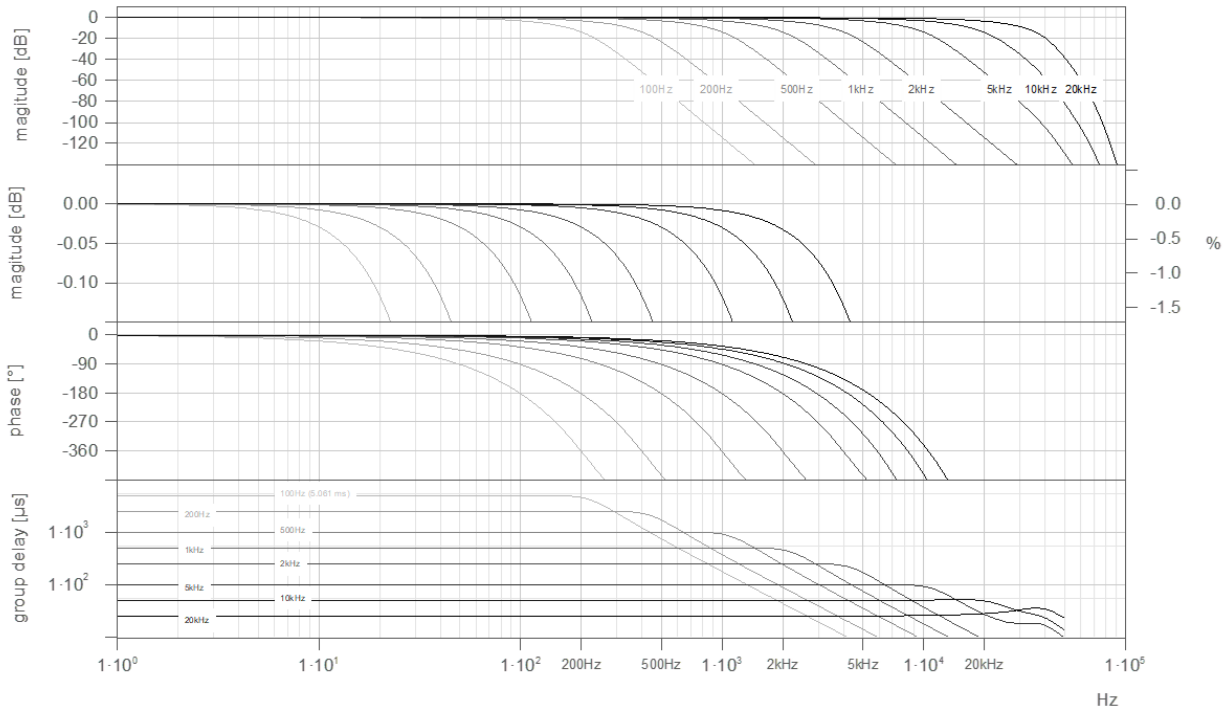

Fig. 22: "Filter type: Bessel" for different cut-off frequencies f_c ($f_{s,prim} = 100 \text{ kSps}$)

Butterworth

Butterworth filters have a maximum flat pass band up to close to the cut-off frequency. Therefore, the sampling rate f_s can be about 2 to 5 times the cut-off frequency f_c . The step response shows a clear overshoot of approx. 16%.

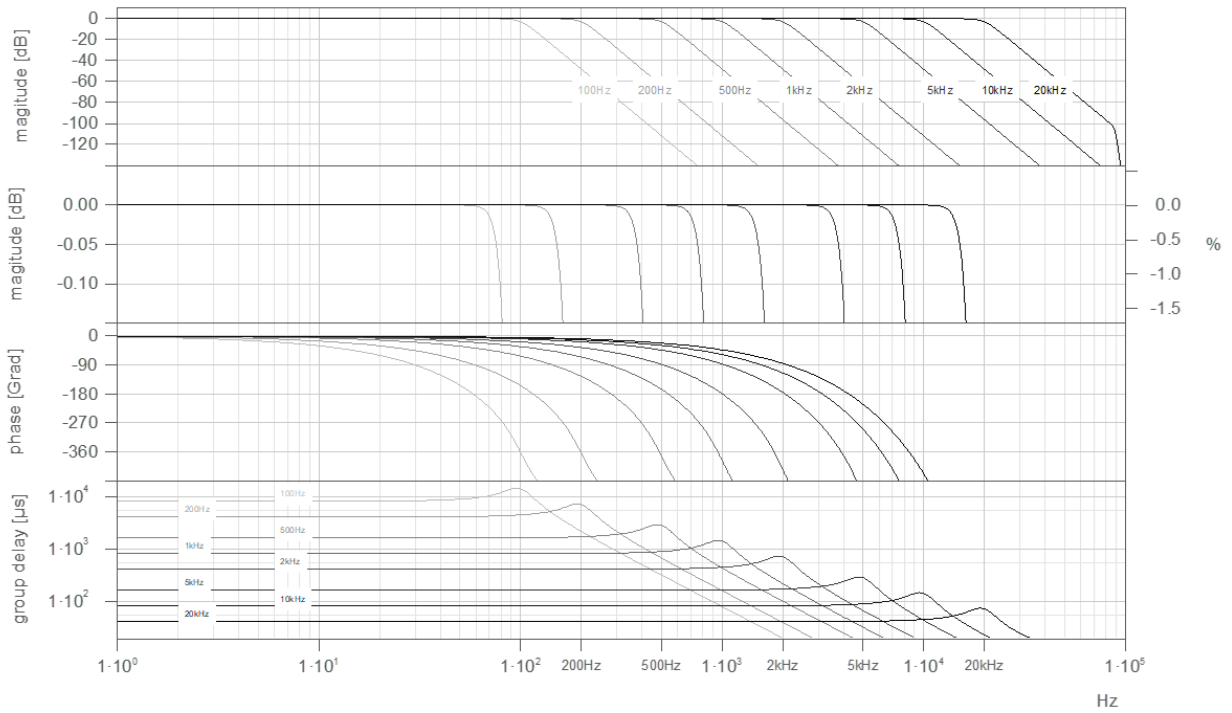

Fig. 23: "Filter type: Butterworth" for different cut-off frequencies f_c ($f_{s\text{ prim}} = 100 \text{ kSps}$)

6.2.6.2.3 Filter setting: "Filter type: without"

With this setting, only the anti-aliasing filter of the first filter stage, which is matched to the primary data rate, is effective. The maximum bandwidth can be achieved with the maximum sampling rate $f_s = f_{s_prim}$. If, on the other hand, a sampling rate $f_s < f_{s_prim}$ is selected, undersampling (aliasing) may occur.

The step response of the first filter stage depends on the product and is approx. 10%, as shown in Fig. 24.

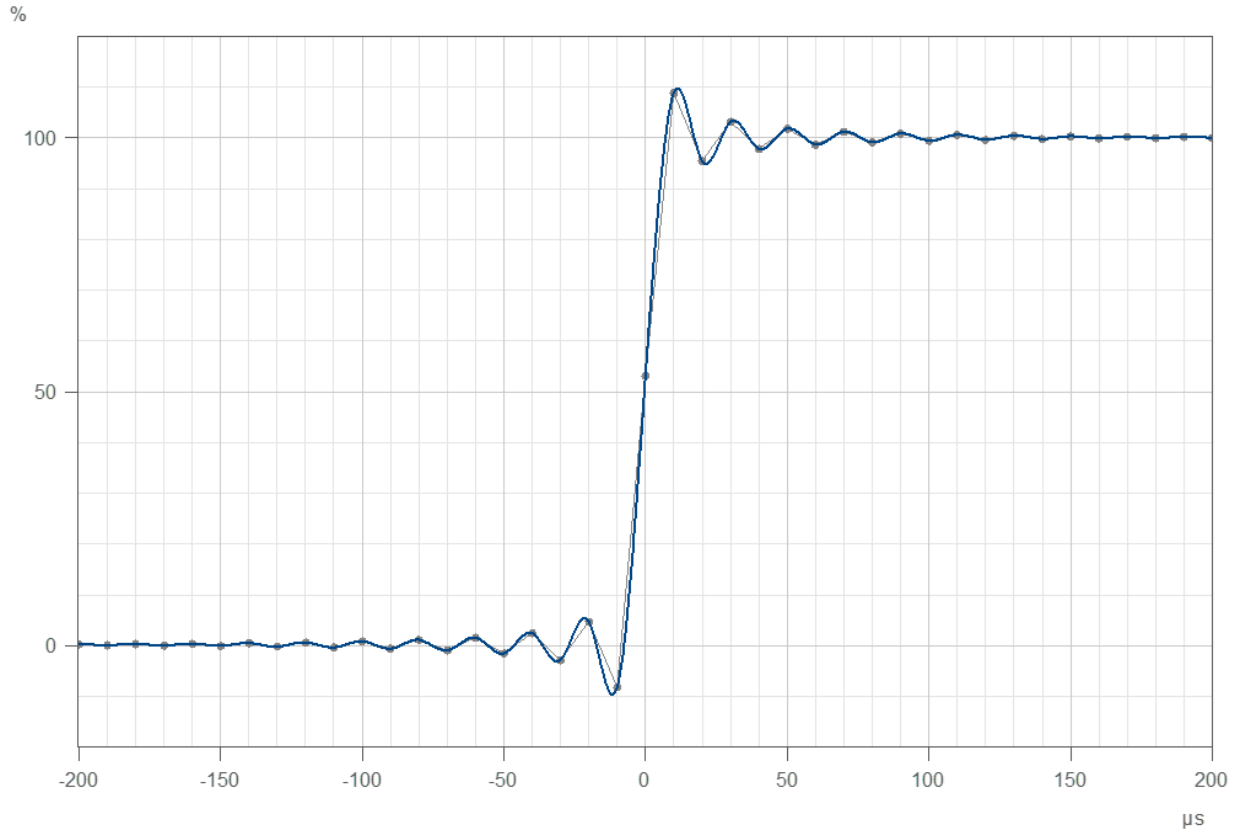

Fig. 24: "Filter type: without" for ARGFT/ICPU-6 at 500 kSps

In some cases, this filter type is not available for $f_s = f_{s_prim}$, in which case only AAF can be set.

7 Measurement types

7.1 Temperature measurement

Two methods are available for measuring temperature. Measurement using a **PT100** requires a constant current, e.g. of 250 μA to flow through the sensor. The temperature-dependent resistance causes a voltage drop which is correlated to a temperature according to a characteristic curve.

When measuring with **thermocouples**, the temperature is determined via the series of voltages of different alloys. The sensor generates a temperature-dependent voltage which is relative to the terminal point on the plug. To find the absolute temperature, the temperature of the terminal point must be known. This is determined with a **PT1000** directly in the terminal plug and requires a special plug type.

The measured voltage is converted into the displayed temperature value according to the characteristics of the temperature scale ITS-90.

A temperature measurement is a voltage measurement whose measured values are converted to physical temperature values by reference to a characteristic curve. The characteristic curve is selected using the "Correction" parameter on the "Measurement mode" tab.

7.1.1 Thermocouples as per DIN and IEC

The following standards apply for thermocouples, in terms of their thermoelectric voltage and tolerances:

Thermocouple	Symbol	max. temp.	defined up to (+)	(-)	
DIN IEC 584-1 (2014-07)					
Iron-constantan (Fe-CuNi)	J	750°C	1200°C	black	white
Copper-constantan (Cu-CuNi)	T	350°C	400°C	brown	white
Nickel-chromium-Nickel (NiCr-Ni)	K	1200°C	1370°C	green	white
Nickel-chromium-constantan (NiCr-CuNi)	E	900°C	1000°C	violet	white
Nicrosil-Nisil (NiCrSi-NiSi)	N	1200°C	1300°C	red	orange
Platinum-Rhodium-platinum (Pt10Rh-Pt)	S	1600°C	1760°C	orange	white
Platinum-Rhodium-platinum (Pt13Rh-Pt)	R	1600°C	1760°C	orange	white
Platinum-Rhodium-platinum (Pt30Rh-Pt6Rh)	B	1700°C	1820°C	n.a.	n.a.
DIN 43710					
Iron-constantan (Fe-CuNi)	L	600°C	900°C	red	blue
Copper-constantan (Cu-CuNi)	U	900°C	600°C	red	brown

If the thermo-wires have no identifying markings, the following **distinguishing characteristics** can help:

- Fe-CuNi: Plus-pole is magnetic
- NiCr-Ni: Minus-pole is magnetic
- Cu-CuNi: Plus-pole is copper-colored
- PtRh-Pt: Minus-pole is softer

The color-coding of compensating leads is stipulated by DIN 43713. For components conforming to IEC 60584: **The plus-pole is the same color as the shell; the minus-pole is white.**

7.1.2 PT100 (RTD) - measurement

RTD (PT100) sensors can be directly connected in 4-wire-configuration. An additional reference current source feeds a chain of up to 4 sensors in series.

7.2 Bridge measurement

This chapter describes the different bridge types and circuits of the bridge channels.

7.2.1 Definition of terms

Strain is the ratio between the original length of a structure and the change in length due to the effect of a force.

$$\varepsilon = \frac{dL}{L}$$

If a strain gauge is attached to a measuring object, the strain is transferred to the measuring grid of the strain gauge when the object is stretched. The change in length caused in the measuring grid causes a change in resistance. There is a proportionality between the change in length and the change in resistance:

$$\varepsilon = \frac{dL}{L} = \frac{dR/R}{k}$$

Legend:	
ε	strain
dL	change in length
L	original length
dR	change in resistance
R	resistance of strain gauge
k	Gauge factor (k factor), describing the ratio of relative length change to the change in resistance

The changes in the resistance caused by the strain are very small. For this reason, a bridge circuit is used to translate the changes in resistance into voltage changes. Depending on the circuit, from one to four strain gauges can be employed as bridge resistors.

Assuming that all bridge resistors have the same value, we have

$$V_a = V_e \cdot \frac{dR}{4 \cdot R} = \frac{V_e}{4 \cdot R} \cdot k \cdot \varepsilon$$

Legend:	
V_a	measurement voltage
V_e	excitation voltage

$$\varepsilon = \frac{V_a \cdot 4}{V_e \cdot k}$$

For concrete measurement tasks, the arrangement of the strain gauges on the test object is important, as well as the circuitry of the bridge. On the "bridge circuit", you can select among typical arrangements. A drawing below this drop down menu shows the position of the strain gauge on your test object and the corresponding bridge circuit. Notes on the selected arrangement are displayed in a text box.

 **Note**

For an easier operation, ranges that are unsuitable are hidden in the operating software.

Scaling for the strain analysis

It is possible to decide whether the strain or the mechanical stress should be determined. In the range of elastic deformation, the axial stress (force / cross section) is proportional to the strain. The proportionality factor is the modulus of elasticity.

Mechanical stress = modulus of elasticity · strain (**Hooke's law**)

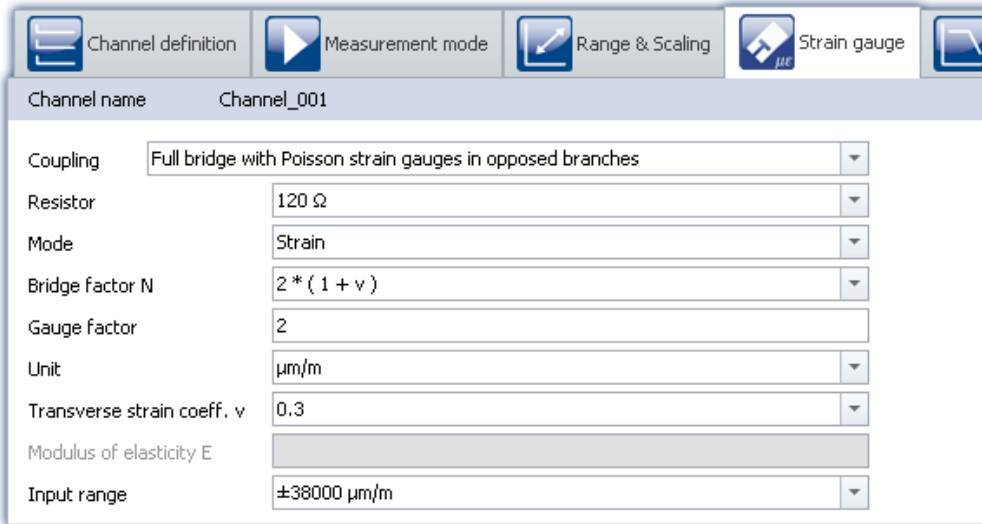

Parameter	Value
Channel name	Channel_001
Coupling	Full bridge with Poisson strain gauges in opposed branches
Resistor	120 Ω
Mode	Strain
Bridge factor N	2 * (1 + ν)
Gauge factor	2
Unit	µm/m
Transverse strain coeff. ν	0.3
Modulus of elasticity E	
Input range	±38000 µm/m

By selecting the "Strain gauge" measurement mode, common bridge circuits and strain gauge arrangements are offered. The scaling can be set using the typical parameters for strain measurements such as K-factor or transverse strain coefficient.

Gauge factor (k factor)

The K-factor is the ratio by which the mechanical quantity (elongation) is transformed to the electrical quantity (change in resistance). The typical range is between 1.9 and 4.7. The exact value can be found in the spec sheet for the strain gauge used. If the value entered for this parameter is outside of this range, a warning message will appear but the module can still be configured.

Unit

When the strain is determined, the readings appear with the unit µm/m.

For the mechanical stress one can toggle between GPa and N/ mm².

$$1 \text{ GPa} = 10^3 \text{ N/ mm}^2$$

Note that the elastic modulus is always in GPa.

Transverse strain coeff.

(poisson's ratio): If a body suffers compression or tension and is able to be freely deformed, then not only its length but also its thickness changes. This phenomenon is known as transversal contraction. It can be shown that for each kind of material, the relative change in length is proportional to the relative change in thickness D. The transversal elongation coefficient (Poisson's ratio) is the material-dependent proportionality factor. The material constant is in the range 0.2 to 0.5.

In bridge circuits where the strain gauges are positioned transversally to the main direction of strain, this constant must be supplied by the user. The ratios for various materials are available in the list box. These values are only for orientation and may need to be adjusted.

Elastic modulus

The elastic modulus E , is a material parameter characterizing how a body is deformed under the action of pressure or tension in the direction of the force. The unit for E is N/mm^2 . This value must be entered for the mechanical stress to be determined. The e -moduli for various materials are available in the list box. These values are only for orientation and may need to be adjusted.

7.2.2 Quarter bridge

7.2.2.1 Quarter bridge with internal completion resistor

This bridge circuit uses an active strain gauge and internal completion resistors for strain measurement of tension, compression or bending. The strain gauge is located in the uniaxial stress field on the measurement object. This strain gauge is supplemented by three passive resistors in the module (internal supplementary resistors) to form a full bridge.

	F_n	M_b	M_t
N	1	1	0

$$\varepsilon = \varepsilon_n + \varepsilon_b + \varepsilon_s$$

$$\varepsilon = \frac{4}{N \cdot k} \frac{V_{IN}}{V_B}$$

$\varepsilon_s = f(\vartheta)$

The configuration does **not** compensate the thermal influence.

With the addition of R_2 to the quarter bridge on the device side, the connection to the sensor resistor is possible in a two- or three-wire circuit.

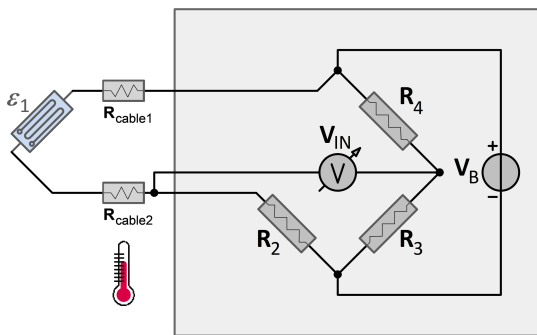

Fig. 25: Quarter bridge in two wire configuration

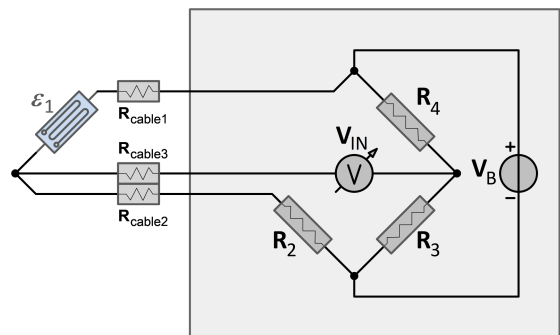
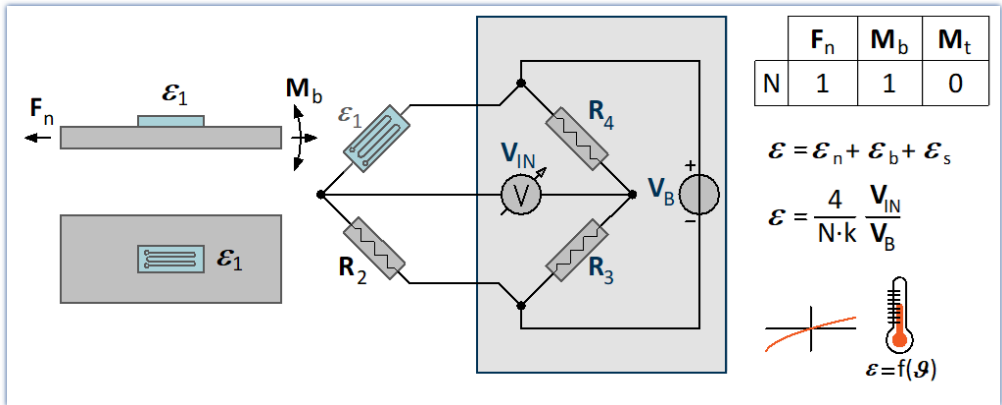

Fig. 26: Quarter bridge in three wire configuration

With the two-wire circuit, the temperature-related changes in the cable resistances R_{cable1} and R_{cable2} do not cancel each other out, which leads to a temperature drift in the measurement. In addition, it is not possible to take into account the signal reduction caused by the cable resistances. The two-wire circuit should therefore only be used if the cable resistances are very small (short cable length, large conductor cross-section) or only low measurement uncertainty is required. The three-wire circuit is preferable.

7.2.2.2 Quarter bridge with external completion resistor

This bridge circuit uses an active strain gauge and an external completion resistor for strain measurement of tension, compression or bending. The strain gauge is located in the uniaxial stress field on the measurement object. This strain gauge is supplemented by two passive resistors in the module (internal supplementary resistors) to form a full bridge.



The configuration does **not** compensate the thermal influence.

7.2.2.3 Quarter bridge - temperature compensated

This bridge circuit uses an **active strain gauge** and a **passive strain gauge** to compensate for the influence of temperature and for strain measurement of tension, compression or bending. The active strain gauge is located in the uniaxial stress field on the measurement object. The passive strain gauge is not under load and is mounted on a component made of the same material and at the same temperature as the active strain gauge.

This strain gauge is supplemented by two passive resistors in the module (internal supplementary resistors) to form a full bridge.

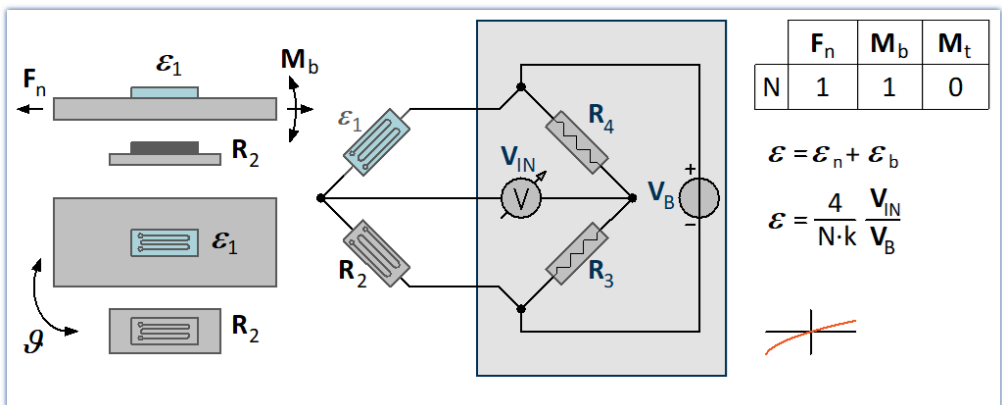

The configuration does compensate the thermal influence (*insensitive to temperature changes*).

7.2.3 Half bridge

7.2.3.1 Poisson half bridge

This bridge circuit uses two active strain gauges for strain measurement of tension, compression or bending. The second strain gauge is positioned on the measurement object transverse to the main strain direction. The transverse contraction is utilized. For this reason, in addition to specifying the K-factor of the strain gauge, it is also important to specify the transverse strain coefficient of the material.

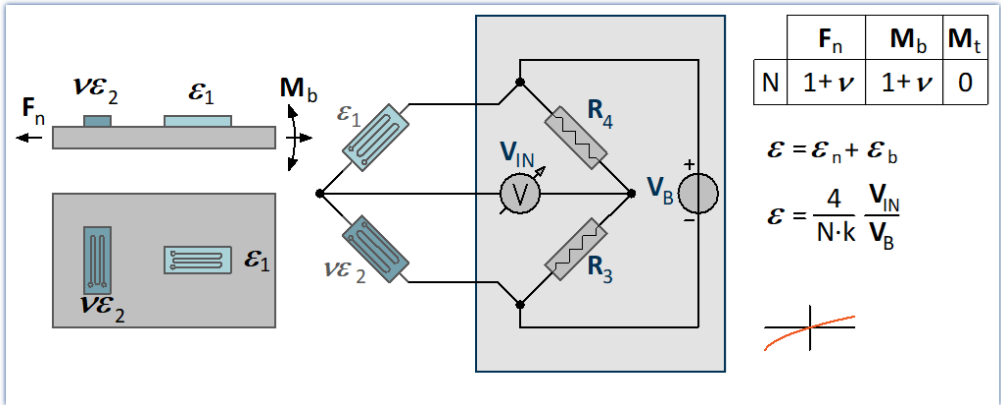

This configuration offers good temperature compensation.

7.2.3.2 Half bridge with two strain gauges in uniaxial direction

Two active strain gauges are placed along one axis under equal tension with opposite directions. Typical **bending beam circuit**: One strain is under compression and the other under equal tension. Double sensitivity for the bending moment, compensates for longitudinal forces, torsion and temperature.

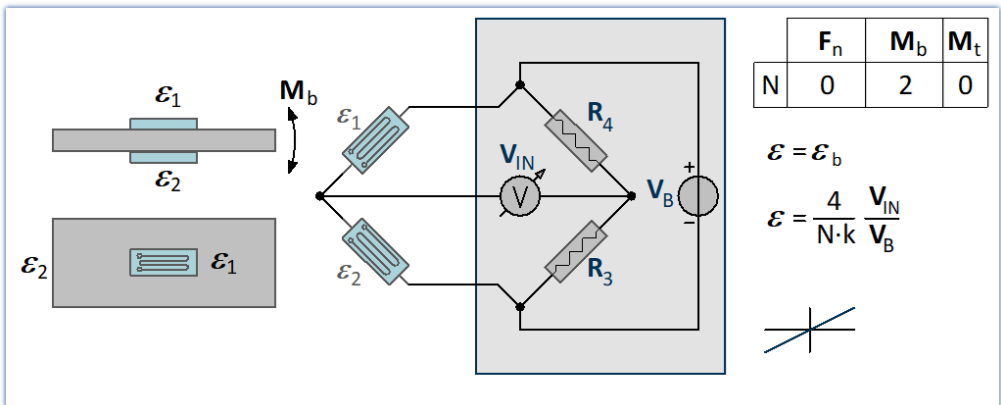

Longitudinal forces, torsion and temperature changes are compensated.

7.2.3.3 Diagonal bridge with two strain gauges in uniaxial direction

This bridge circuit uses two active strain gauges on diagonally opposite sides of the structure to measure strain in tension and compression respectively.

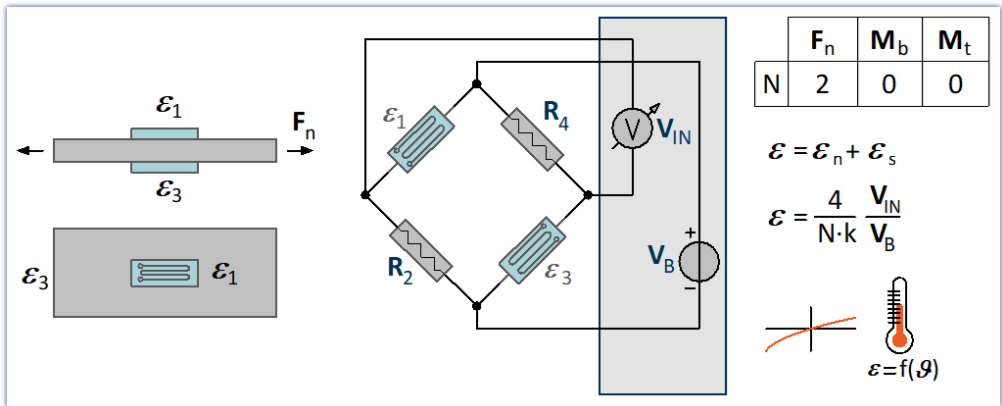

The configuration does **not** compensate the thermal influence.

7.2.3.4 Diagonal bridge - temperature compensated

This bridge circuit uses two active strain gauges that are diagonally connected and located on diagonally opposite sides of the structure to measure strain in tension or compression. They are complemented by 2 passive strain gauges, which are mounted on a component made of the same material and at the same temperature to compensate for the influence of temperature.

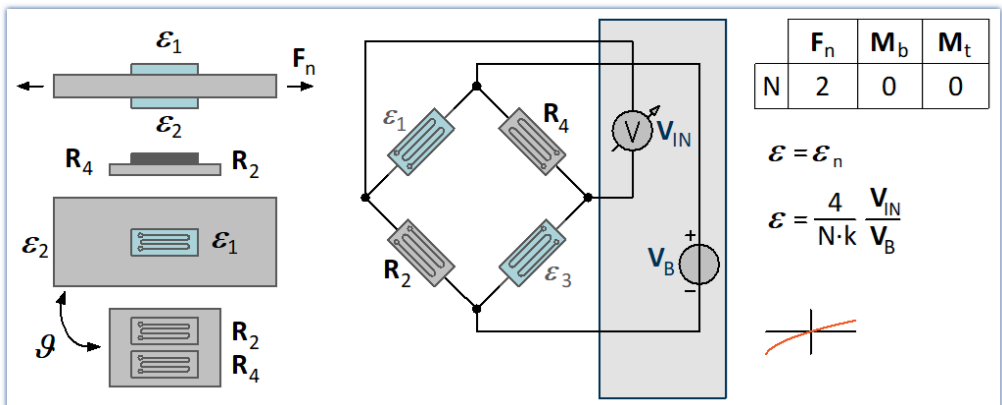

The configuration does compensate the thermal influence (*insensitive to temperature changes*).

7.2.3.5 Half bridge - general strain gauge

Freely configurable half-bridge circuit with bridge completion in the measuring device. N must be selected from a list.

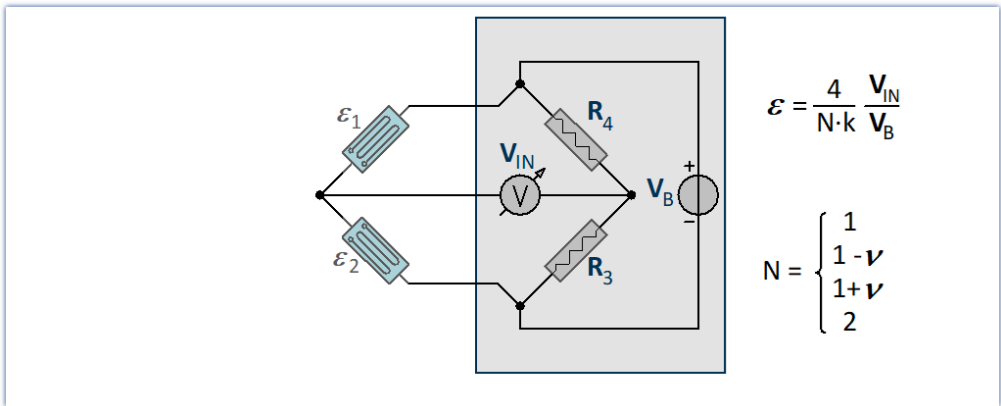

7.2.4 Full bridge

7.2.4.1 Full bridge with four strain gauges - bending beam

General full bridge circuit for the bending moment

This bridge circuit uses four active strain gauges. Two of them are under compression and two are under equal tension, located on opposite sides of the structure.

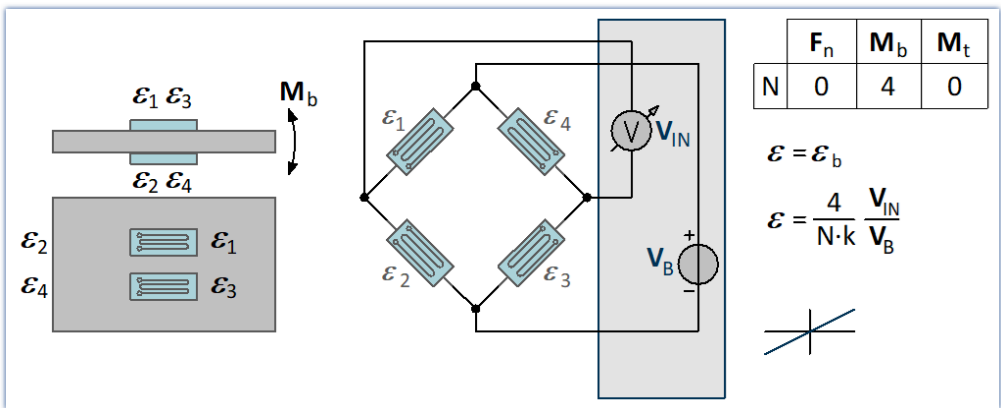

The sensitivity of the bending moment is increased. At the same time, longitudinal force, torque and temperature are compensated for.

7.2.4.2 Full bridge consisting of two Poisson half bridges - installed on one side of the structure

This bridge circuit uses a full bridge with four active strain gauges. Two active strain gauges are supplemented by two transversely arranged strain gauges to form Poisson half bridges, which are located in the diagonally opposite bridge branches (*tension rod arrangement*). This circuit results in a high sensitivity by utilizing the transverse contraction and the normal strain with good compensation of the temperature influence. Strain measurement of **tension, compression or bending**.

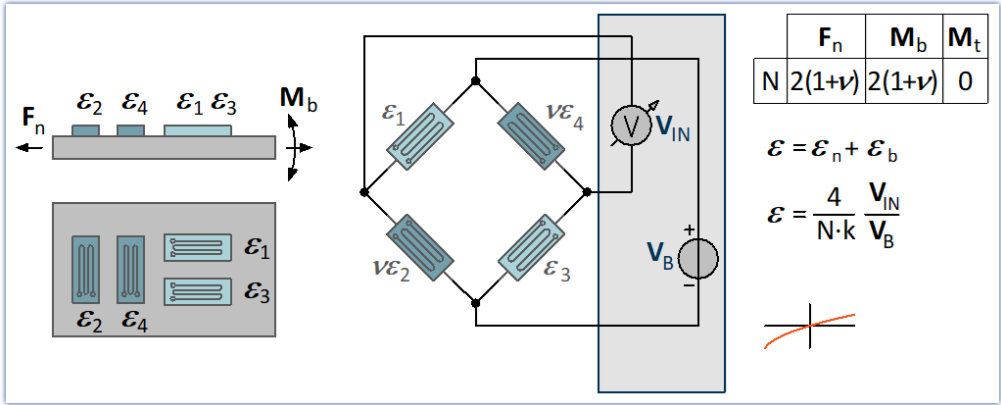

In this circuit, the specification of the transverse strain coefficient of the material is important. The arrangement is **insensitive** to temperature changes.

7.2.4.3 Full bridge consisting of two Poisson half bridges - installed on opposite sides of the structure

This bridge circuit uses a full bridge with four active strain gauges. Two active strain gauges are supplemented by two transversely arranged strain gauges to form Poisson half bridges, which are located in the diagonally opposite bridge branches. This circuit results in a high sensitivity by utilizing the transverse contraction and the normal strain with good compensation of the temperature influence. Suitable for strain measurement of **tension or compression**.

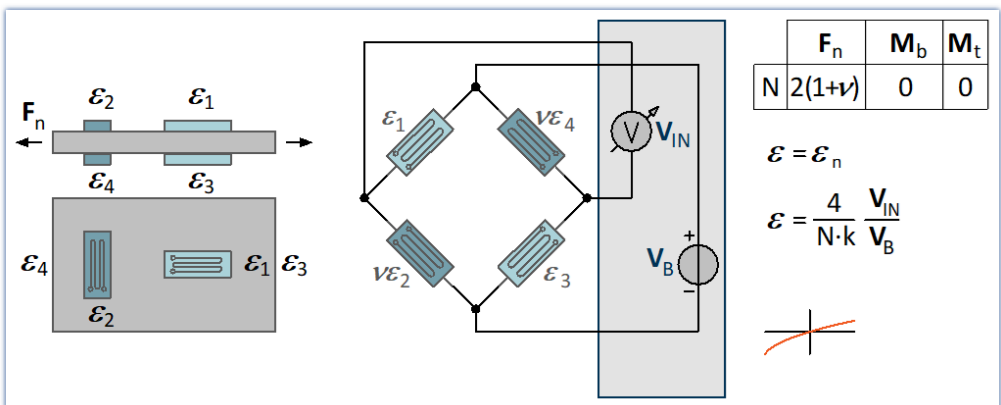

This circuit offers **good** compensation for temperature influences.

7.2.4.4 Full bridge - torsion measurement

This bridge circuit uses a full bridge with four active strain gauges, each applied at an angle of 45° to the main axis of the structure. This circuit results in a high sensitivity with good compensation of the temperature influence. It is insensitive to tension or pressure, bending and temperature changes.

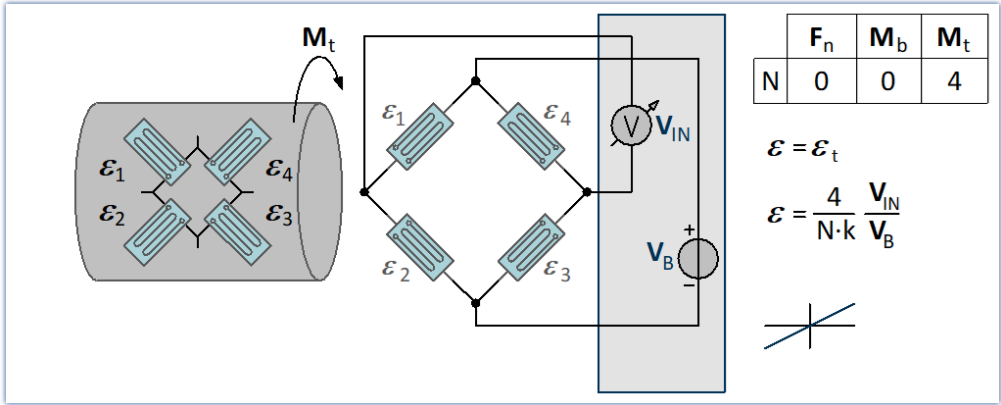

This circuit offers **good** compensation for temperature influences.

A measurement on the torsion bar can have several objectives:

1. To determine the normal and shear stresses for strength considerations.
2. To determine the effective torsional moment M_t , from which the transmitted power P can be calculated for rotating shafts.
3. Determining the angle of displacement or the angle of torsion.

! Note

Only case 1 is possible

imc STUDIO only supports the first case.

7.2.4.5 Full bridge - general strain gauge

Freely configurable full bridge circuit. The bridge factor N must be specified via list selection.

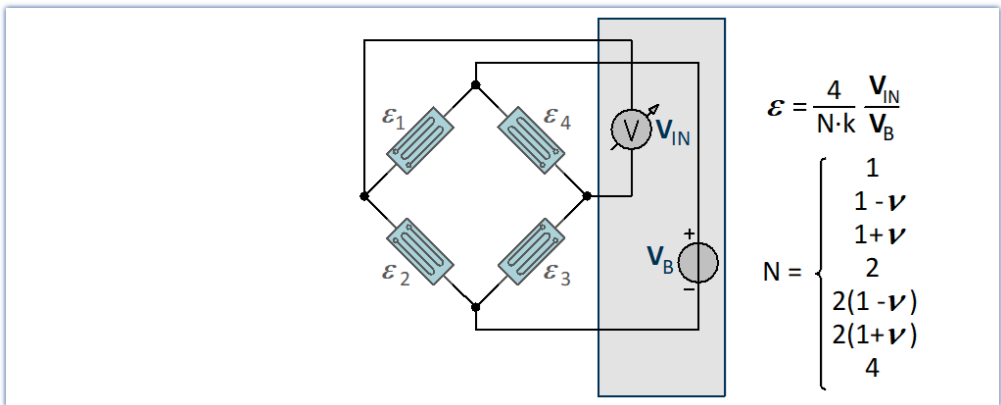

8 Measurement modules

8.1 B-4

The B-4 module belonging to the imc ARGUSfit series is a 4-channel measurement amplifier that can be used in conjunction with an imc ARGUS system (or base unit) to which it is directly docked with its housing.

Individually isolated, configurable differential channels capturing:

- Strain gauges, bridge sensors, full-, half and quarter bridge
- Voltages (25 mV to 10 V)

For powering external sensors a software selectable sensor supply is integrated.

Reference

- Technical Specs: [B-4](#)^[86], status LED codes: [B-4](#)^[87] and the pin configuration: [signal connection](#)^[109]
- You will find a description of the click connection in the section: [Click mechanism](#)^[17].

8.1.1 Bridge measurement

8.1.1.1 Quarter bridge

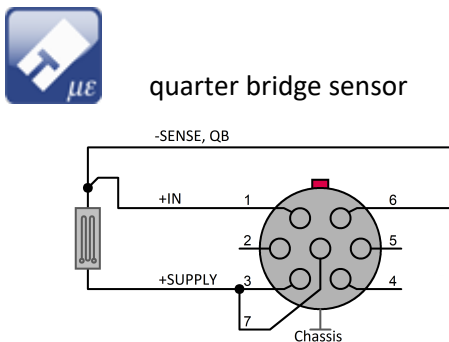

Fig. 27: Connection schematic B-4 quarter bridge

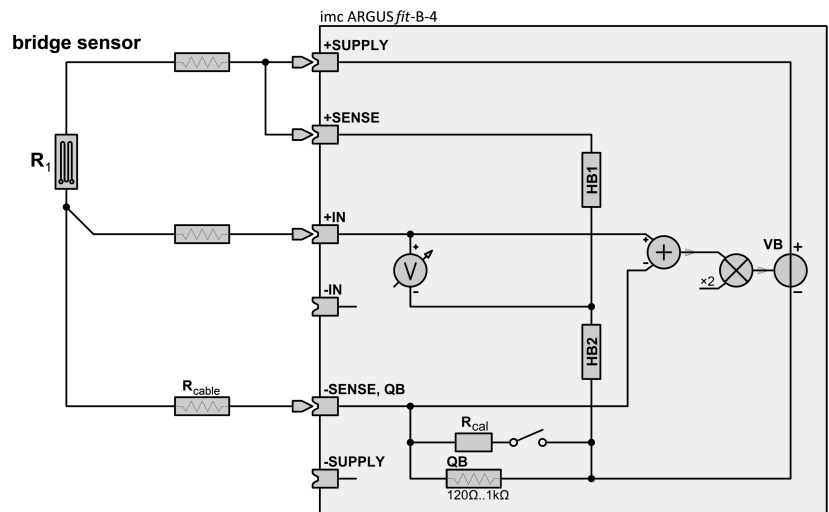

Fig. 28: Block schematic B-4 quarter bridge

The +SENSE sensor input is active in "**Quarter bridge**" measuring mode.

8.1.1.2 Half bridge



half bridge sensor
potentiometric sensor
piezo-resistive sensor

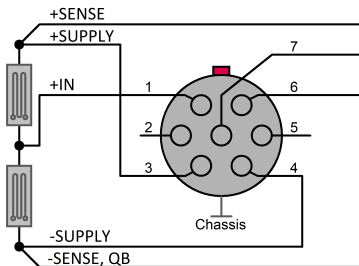

Fig. 29: Connection schematic B-4 half bridge

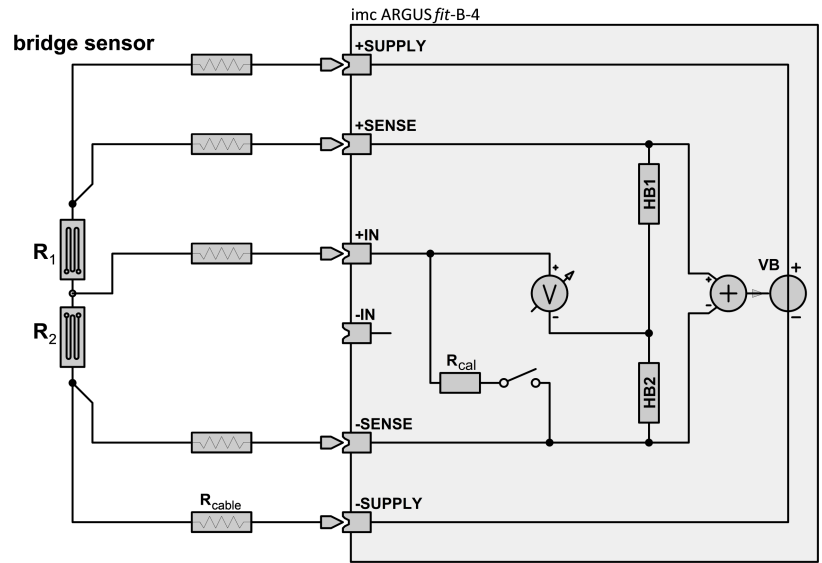

Fig. 30: Block schematic B-4 half bridge

In the **"half bridge"** measuring mode, the sensor inputs \pm SENSE of the sensor supply are active. They must always be connected to the \pm SUPPLY supply connections.

If only one of the two sensor inputs is connected to the sensor (e.g. cable fracture), the [LED next to the socket](#) ⁸⁷ signals the error.

8.1.1.3 Full bridge



full bridge sensor

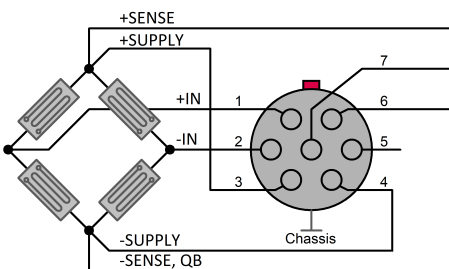

Fig. 31: Connection schematic B-4 full bridge

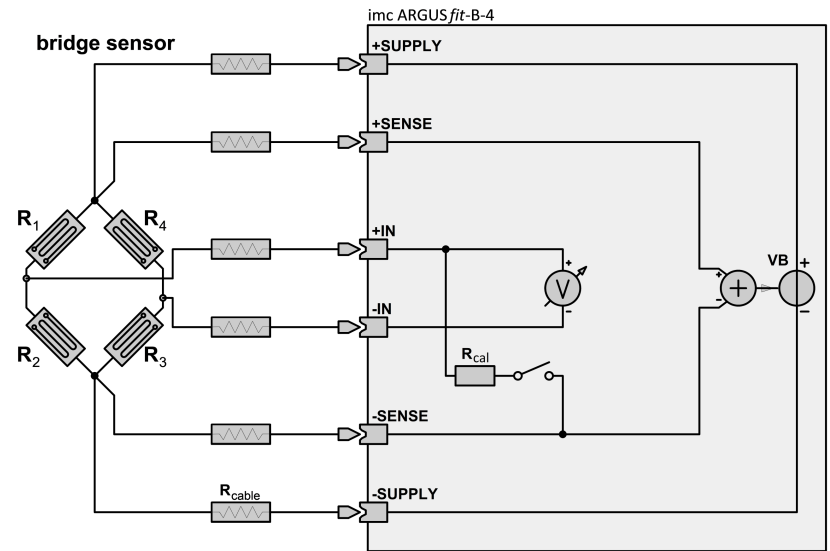

Fig. 32: Block schematic B-4 full bridge

In the **"full bridge"** measuring mode, the sensor inputs \pm SENSE of the sensor supply are active. They must always be connected to the \pm SUPPLY supply connections.

If only one of the two sensor inputs is connected to the sensor (e.g. cable fracture), the [LED next to the socket](#) ⁸⁷ signals the error.

8.1.2 Sense wires

The lead resistances between the sensor supply and the bridge resistor reduce the supply voltage applied to the bridge and thus influence the measurement deviation. This is referred to as **cable attenuation**. To compensate for this systematic dependency, the supply voltage can be increased by the voltage losses on the cable.

Additional measuring cables (\pm SENSE) are required to measure the effective voltage at the sensor. A distinction is made between the connection of the measuring bridge with and without cable attenuation compensation.

4-wire configuration

If the lead resistances between the measurement device and the sensor are small (large cable cross-section, short cable length), then their influence on the measurement deviation is low. If this low cable attenuation is tolerable, the sensor inputs (\pm SENSE) of the sensor supply (\pm SUPPLY) can either be connected in pairs or remain unconnected. The lead resistances are then not compensated.

For a measurement deviation of less than 0.1%, the cable resistance must be less than $1/2000$ times the bridge resistance R_b , i.e. 0.06Ω for $R_b=120 \Omega$. This corresponds to approx. 0.5 m of copper cable with a cross-section of 0.14 mm^2 .

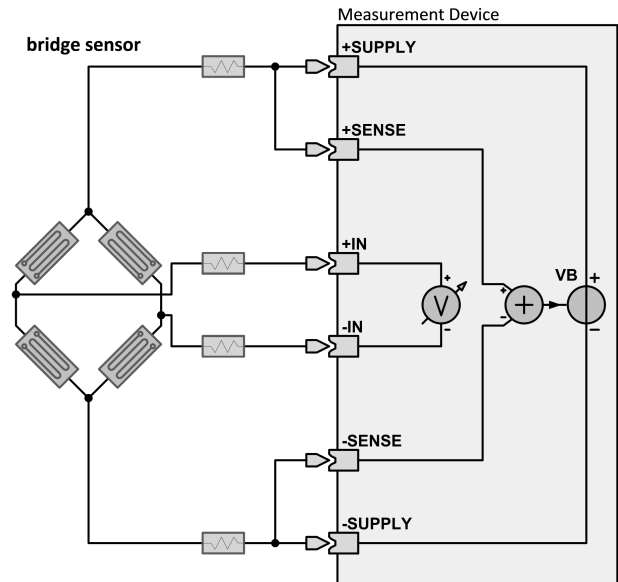

Fig. 33: 4-wire configuration (B-4)

6-wire configuration

The sensor inputs (\pm SENSE) can be wired to compensate for the lead resistances. For this purpose, the sensor inputs must be connected to the bridge via a separate cable (connection points of bridge and supply line of the sensor supply, see fig. 34). The supply voltage is then increased until the supply voltage at the sensor reaches the nominal voltage and the voltage drops at the cable are thus compensated. The compensation range for cable resistances is approx. 10% of the bridge impedance.

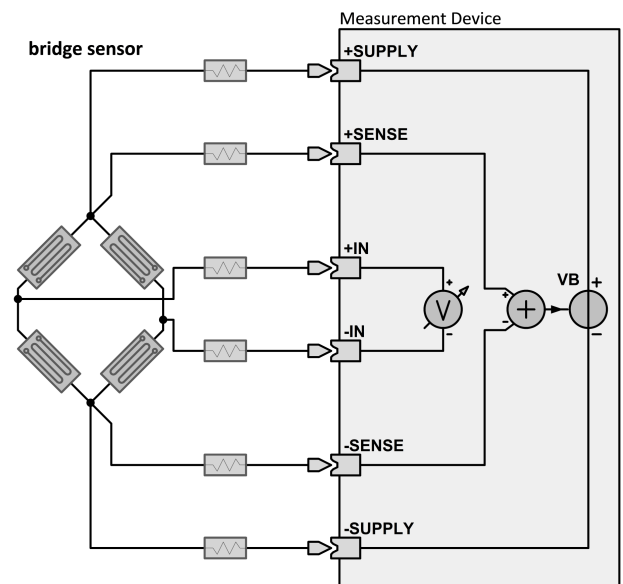

Fig. 34: 6-wire configuration (B-4)

8.1.3 Sensor supply

Each measurement input of the B-4 has a **voltage source** which can be used to supply transducers, sensors, etc. with power. The voltage can be set independently of the measurement inputs.

8.1.4 Adjustment of the pre-trim

Usually, a bridge circuit is unbalanced even though the bridge sensor has not yet been subjected to the target variable (e.g. mechanical voltage, force). This pre-trimming leads to a non-zero electrical signal. The causes of a pre-trimmed bridge could be a deflection caused by the sensor mounting, the component tolerances of the bridge resistors or an apparent strain of strain gauge resistors due to temperature influences. Often the zero point of the target value is also unknown or cannot be reached due to the application conditions (e.g. mechanical load).

When the bridge is adjusted, this pre-trimming is determined and used to shift the measuring range and for shunt calibration. After the adjustment process, the measured value display is zero. Subsequently, measurements over the entire measuring range are possible.

The bridge adjustment must always be used for compensation of the pre-trim and must not be equated with the taring option. Taring causes the current display value to be subtracted from the future values and (in contrast to bridge adjustment) is carried out after a calculation with a characteristic curve. The display is therefore changed, but the measuring or modulation range remains unchanged.

The following table shows the trim that can be suppressed without restricting the measuring range. (The linear modulation range is the measuring range extended by the balancing range. For example, the dynamic range is -15.1 mV/V to +15.1 mV/V for the "10 mV/V" measuring range with a 5 V supply.)

nom. range [mV/V]	Bridge supply [V]	Balancing range [mV/V]			
		5	2.5	1	0.5
1000 ¹		330	330	210	210
500		160	160	100	100
250		80	80	50	50
100		20	20	50	50
50		10	10	25	25
25		5	5	10	10
10		5	5	8	
5		5	5		
2.5		2.5			

After changing the measuring range, a zero point adjustment is recommended, otherwise a deviation may occur. The pre-trim compensation is not transferred when the measuring range is changed.

1 only full bridge

8.1.5 Balancing and shunt calibration

The shunt calibration is primarily used to check measuring chains. For this purpose, the measuring input has several shunt resistors that can be connected in parallel to the sensor resistors under software control. This allows a defined sensor signal to be simulated.

The measuring input has sensor inputs which can be used to effectively prevent a change in sensitivity caused by the lead resistors. As this compensation is much more precise than the shunt resistances of approx. 0.1% and also permanently takes into account changes in the lead resistances (temperature), the shunt calibration should only be used to adjust the measuring chain if the sensor inputs are not used.

R_{cal} \ RB	120 Ω	350 Ω	1000 Ω
	V/V	V/V	V/V
59.940 k Ω	-500.00 μ	-1.4555 m	-4.1363 m
174.83 k Ω	-171.54 μ	-500.00 μ	-1.4259 m
499.50 k Ω	-60.053 μ	-175.11 μ	-500.00 μ

Table 1: Shunt calibration for full and half bridges

R_{cal} \ RB _{QB}	120 Ω	350 Ω	1000 Ω
	V/V	V/V	V/V
174.83 k Ω	-171.54 μ	-500.00 μ	-1.4259 m

Table 2: Shunt calibration for quarter bridges

8.1.6 Voltage measurement

In voltage measurement mode, voltage drops on the sensor supply lines are not compensated. The sensor inputs of the sensor supply are inactive.

Note

If the sensor or the input is not connected to the sensor supply, or if the sensor supply is not used, the sensor supply must be set to "-" (off, 0 V).

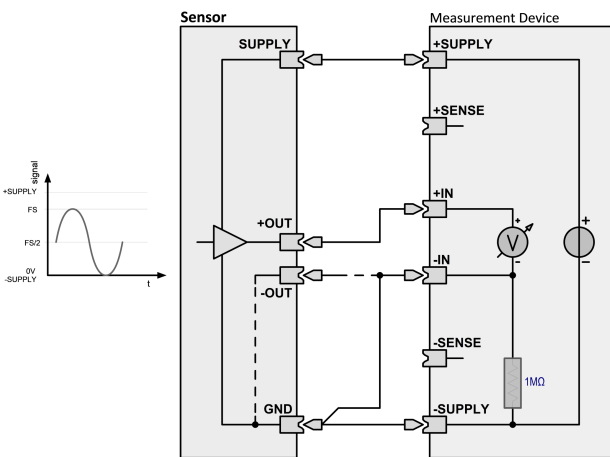

a) sensor with single-end output

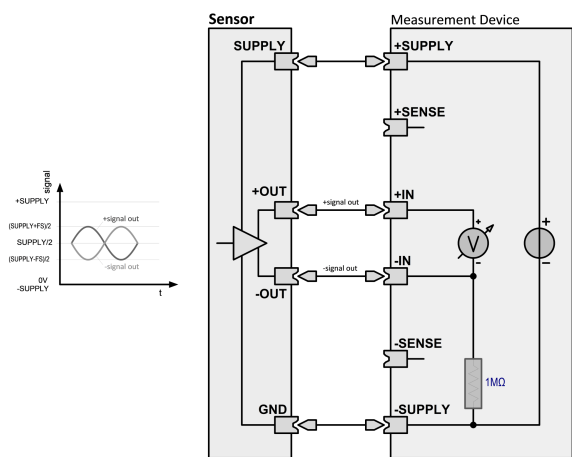

b) sensor with differential output

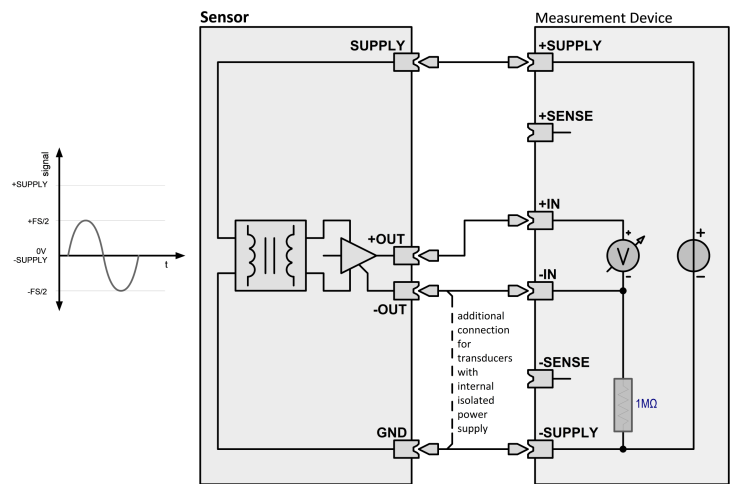

c) sensor with isolated output

8.2 UTI-6

The UTI-6 is a 6-channel universal measurement amplifier. Individually isolated, configurable and differential channels capture:

- Voltage (25 mV to 60 V)
- Current (20 mA sensors)
- Temperature (PT100, PT1000)
- Resistance (e.g. NTC)

For powering external sensors a software selectable sensor supply is integrated.

If a measurement input is deactivated by the user or if the device is not supplied with energy, then the impedance between the two measurement inputs +IN and -IN is approximately 1 MΩ.

Reference

- Technical Specs: [UTI-6-SUP](#)^[91], status LED codes: [UTI-6-SUP](#)^[92]
- Pin configuration [signal connection](#)^[109]
- [Please find here information describing the click mechanism.](#)^[17]

8.2.1 Voltage measurement

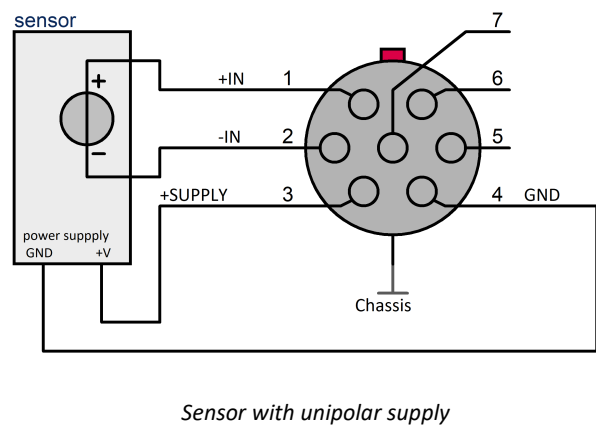
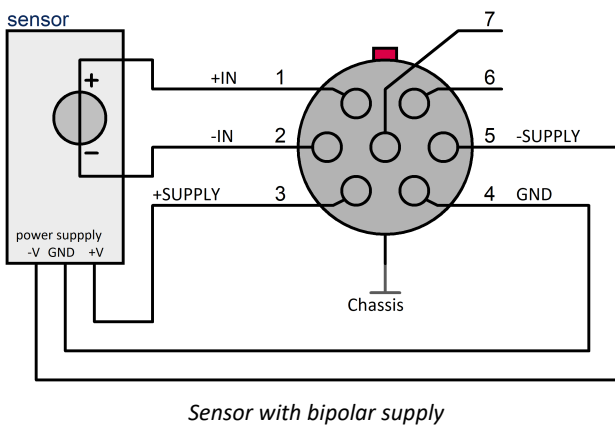
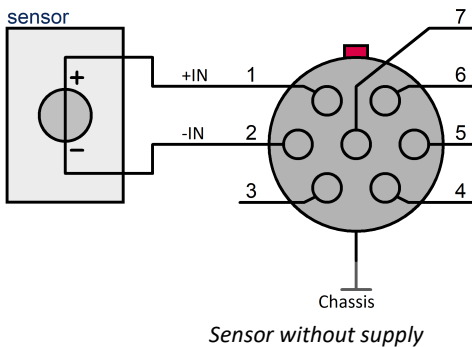

8.2.2 Current measurement

The connection between **-IN** (pin 2) and **-I** (pin 7) must be made directly in the connector and the current must be applied to **-I** (pin 7). Any additional cable lead would falsify the internal 25 Ω shunt applied.

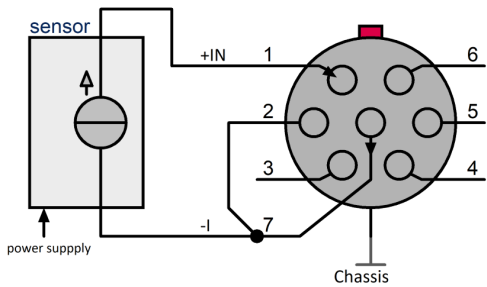

Fig. 35: current measurement I (general, UTI-6)

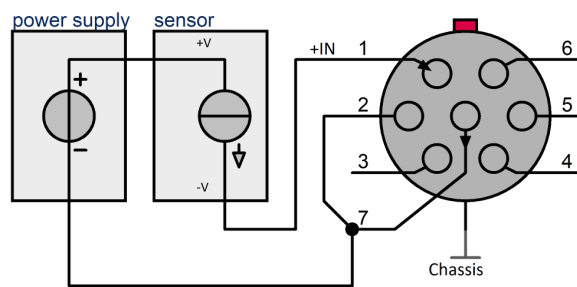

Fig. 36: current measurement II (UTI-6)

For current measurement, the current is passed through the device from "+IN" to "-I" and generates a voltage drop of approx. 25 mV per 1 mA, as shown in figures above. The current is powered by an external source with its own supply. With two-wire sensors, it is connected in series to the sensor, see Fig. 36.

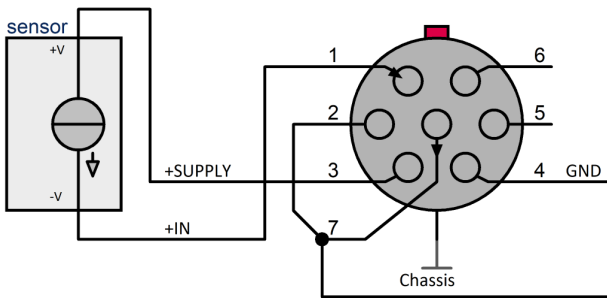

Fig. 37: unipolar sensor supply 5 V to 15 V (UTI-6)

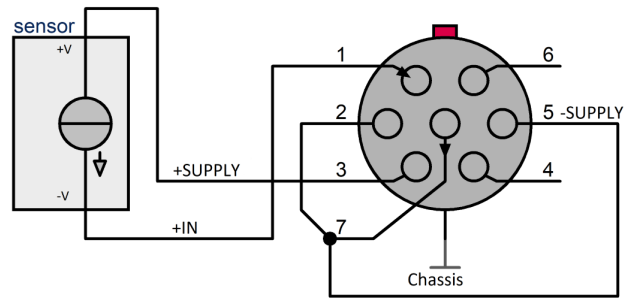

Fig. 38: unipolar sensor supply 24 V (UTI-6)

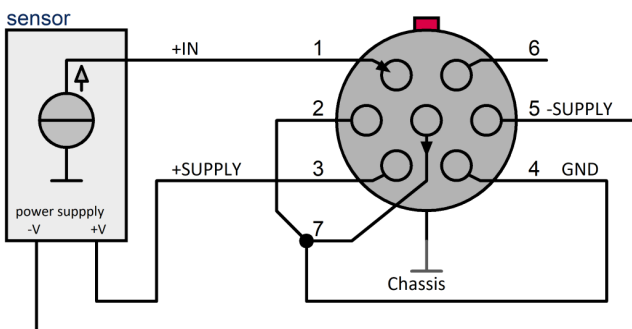

Fig. 39: 3-wire sensor and bipolar sensor supply ±15 V (UTI-6)

If the sensor is supplied by the measuring device, a distinction must be made between unipolar and bipolar supplied sensors. This can be recognized by the number of connections. Sensors with unipolar supply have two connections, sensors with bipolar supply have three connections. In the figures above, these two types are referred to as "Two-Wire Current Loop" and "Three-Wire Current Loop" respectively.

- The sensors with two-wire connection (unipolar supply) are encoders with the classic 0 mA/4 mA ... 20 mA current loop. The signal has only positive polarity. If the current loop requires a supply greater than 15 V (standard), the sensor must be connected to +SUPPLY and -SUPPLY according to Fig. "unipolar sensor supply 24 V". For the setting of the supply voltage of ±12 V, for example, 24 V are available for the current loop.

- Sensors with three-wire connection (bipolar supply) can supply signals of both polarity, see Fig. "3-wire sensor".

8.2.3 Resistance measurement

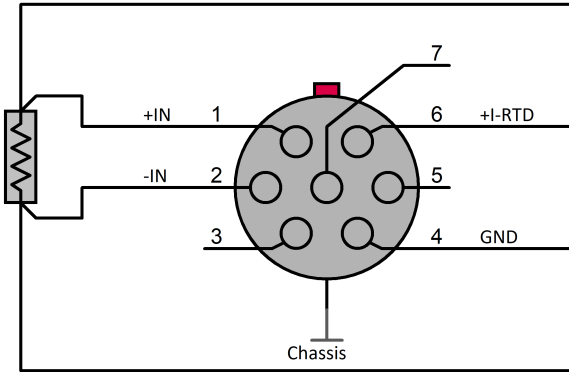

Note

Ensure good isolation!

The deviation due to the isolation resistance is:

$$\epsilon = \frac{R}{R+R_{iso}} \cdot 100\%$$

A source supplies the resistance to be measured with a constant current. This creates a voltage across it, which is detected by the measuring input and used to calculate the resistance value. The voltage should be taken with separate lines in four-wire circuit (Kelvin connection) so that the current-carrying conductor resistances do not distort the result.

If the line resistances are negligibly small compared to the resistance, the two-wire circuit can be used. The measurement inputs +IN and -IN must be connected directly to +I-RTD or GND in the connector. So that the influence of the cable resistances remains smaller than the deviation of the measuring channel, the distance between resistance and measuring module should remain smaller than the values from the following table:

Cross section [mm ²]	resistance per conductor length Cu at 20°C [mΩ/m]	corresponding to AWG
0.14	127	26
0.25	71	23
0.34	52	22
0.38	47	21
0.5	35	20

max. cable length for 2-wire configuration [m]		cross section				
measurement range	supply current	0.14 mm ²	0.25 mm ²	0.34 mm ²	0.38 mm ²	0.5 mm ²
100 kΩ	25 μA	142				
50 kΩ	50 μA	71	126			
25 kΩ	0.1 mA	35	63	86	96	126
10 kΩ	0.25 mA	14	25	34	38	51
5 kΩ	0.5 mA	7	13	17	19	25
2.5 kΩ	1 mA	4	6	9	10	13
1 kΩ	1.25 mA	1.4	3	3	4	5
500 Ω	1.25 mA	0.7	1.3	2	2	3
250 Ω	1.25 mA		0.6	0.9	1.0	1.3
100 Ω	1.5 mA					0.5

8.2.4 RTD measurement

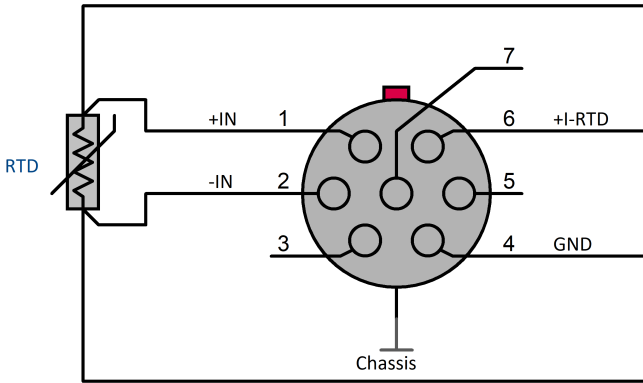

The following table shows a rough approximation of the deviation per meter (copper cable, two-wire connection):

Cross section [mm ²]	PT100 [K/m]	PT1000 [K/m]
0.08	1.2	0.12
0.14	0.7	0.07
0.25	0.4	0.04
0.34	0.3	0.03

Regardless of the type of connection (two-, three- or four-wire connection), good isolation must be ensured!

T [°C]	ΔT (PT100) [K]	ΔT (PT1000) [K]
-200	0	0
0	0	-0.03
100	-0.01	-0.05
300	-0.01	-0.13
500	-0.02	-0.24
850	-0.05	-0.52

Table: Measurement error for isolation resistance of 10 MΩ

8.2.5 Sensor supply

Each measurement input of UTI-6-SUP has a **voltage source** which can be used to supply transducers, sensors, etc. with power. The voltage can be set independently of the measurement inputs. The sensor supply of the UTI-6-SUP is **bipolar**, i.e. it consists of a positive (+SUPPLY) and a negative (-SUPPLY) voltage source which are symmetric (e.g. $\pm 15\text{ V}$) with regard to their common connection (GND), see Fig. 39. Loads can be connected requiring either **one or two supply voltage levels**. For supply voltage requirements above 15 V, transducers must be connected between $\pm\text{SUPPLY}$. In this case, however, the operating software must be set for one half of the voltage (e.g. $\pm 12\text{ V}$ for a 24 V sensor). The supply range from $\pm 2.5\text{ V}$ to $\pm 15\text{ V}$ or equivalently +5 V to +30 V covers nearly all commonly available sensors. But if this is still not sufficient, it is possible to combine the sensor supplies for adjacent inputs.

The available sensor supply power is approx. 0.5 W per channel (for more information see [Table of technical specs](#)). In case of overload or short-circuit, the channel's power supply unit switches off, indicated by the **red shining status indicator**. The voltage only returns after the configuration process or after switching the device off and then on again.

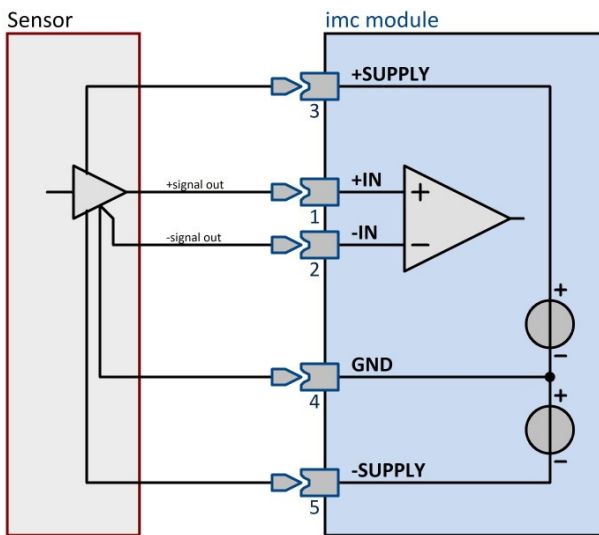

Fig. 40: UTI-6 with a non-isolated transducer in the sensor

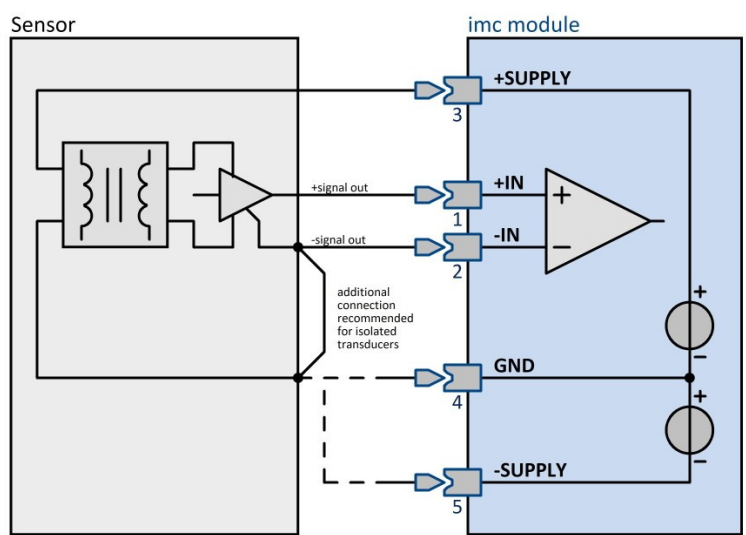

Fig. 41: UTI-6 with isolated transducer in the sensor

The sensor supply is electrically isolated from the device ground and also from other input channels. The voltages at the inputs ($\pm\text{IN}$) should be within the range of the supply voltage ($\pm\text{SUPPLY}$). Between the input voltage ($\pm\text{IN}$) and the inputs sensor supply ($\pm\text{SUPPLY}$), the voltage difference may not exceed $\pm 50\text{ V}$ - above approx. 200 V the device might get damaged. This condition is usually not a problem because all passive sensors and most transducers generate their signal output voltage from the sensor supply with an electrical connection. We recommend an additional connection for isolated transducers, if the supply lines and the signal outputs of the transducer are galvanically isolated, see Fig. 41.

Note

Short circuit

In case of a short circuit, the module is fully protected. For a complete recovery, the module may have to be switched on again.

8.3 ICPU-6





The ICPU-6 is a 6-channel measurement amplifier. Individually isolated, conditioned and configurable differential channels capture:

- IEPE or ICP sensors (current fed 4 mA).
- Voltage (AC and DC coupling)

Direct connection of IEPE compatible sensors (ICP™, DELTATRON®, PIEZOTRON® sensors) is made via BNC connectors.



Reference

- [Technical Specs ICPU-6](#) 
- Status LED codes: [ICPU-6](#) 
- Pin configuration [signal connection](#) 
- [Please find here information describing the click mechanism.](#) 

8.3.1 Voltage measurement

A voltage divider is effective in the respective voltage ranges; depending on the range and measuring mode, an input impedance results, see [technical specs](#) .

8.3.2 Current fed sensors

The use of ICP e.g. DeltaTron-sensors is supported by a 4 mA current source.

8.4 CAN FD

The CAN FD interface is a clickable module for the modular imc ARGUSfit system. Together with the analog ARGUSfit measurement amplifiers, several of these interfaces [can be clicked](#)^[17] to an imc ARGUSfit base. The ability to acquire CAN-based measurement data and log channels can thus be flexibly added to such a measurement system.

Two CAN nodes per module are provided at DSUB-9 sockets with [standardized pinout](#)^[110]. For the logical decoding of the channels, the module has a local intelligence in the form of a processor. This relieves the ARGUSfit base unit and the overall system is easily scalable in its total performance even with several interfaces.

Power-via-CAN

If imc CANSAS modules are used as CAN-based sensors/signal sources, they can be supplied from the ARGUS device and do not require their own power supply.

The supply voltage of the [base unit](#)^[20], [Fiber Converter](#)^[21] and the [UPS-NiMH module](#)^[22] can be switched on for the first CAN node "CAN 1" of each interface module for the connected imc CANSAS modules. To do this, the "Power-via-CAN switch" is activated in the CAN-Editor on the "Node definitions" page. The maximum current is limited to 1 A and results from the sum of the powers of the connected imc CANSAS modules divided by the supply voltage.

Device connection with a Y-adaptor

The CAN interfaces from imc provide exactly one DSUB9 connection for each node. Connection to a CAN bus therefore requires a Y-adaptor.

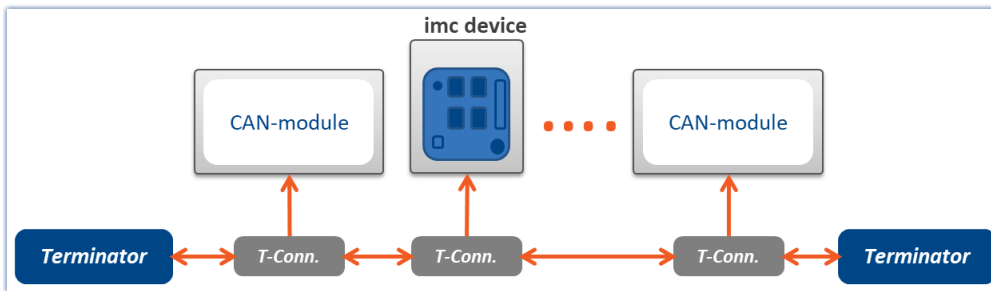

Device connected with Y-adaptor

To guarantee a CAN data transfer rate of 1 Mbit/s, the **maximum length** for the pathway through a Y-adaptor is **30 cm**.

In this case it doesn't matter whether the other CAN participants are connected with or without a Y-adaptor. The diagram shows just one of several connection possibilities.

Connecting terminators

- Terminators with 124 Ω in accordance with CiA.
- Terminators are connected between pin 2 and 7.
- Terminators must be used at both ends of the bus. No further terminators are allowed.

Terminator in device

Devices equipped with CAN-bus interface, can switch a terminator resistor internal via software. If the device is connected at one end of the CAN line, an external Y-cable with terminator is not needed.

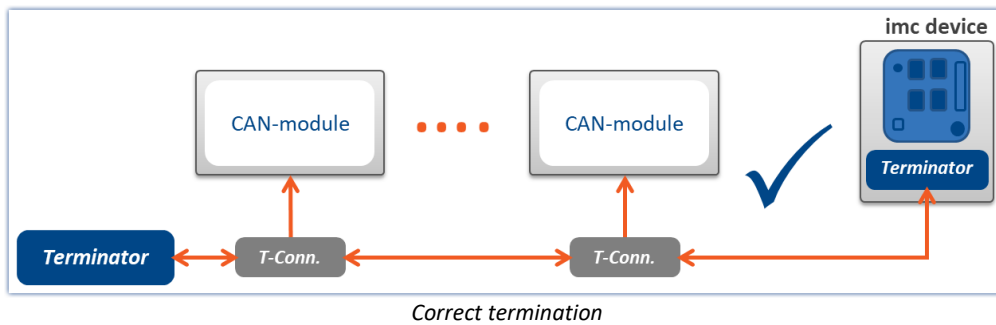

Warning

If the CAN-bus is already terminated correctly, that option cannot be used!

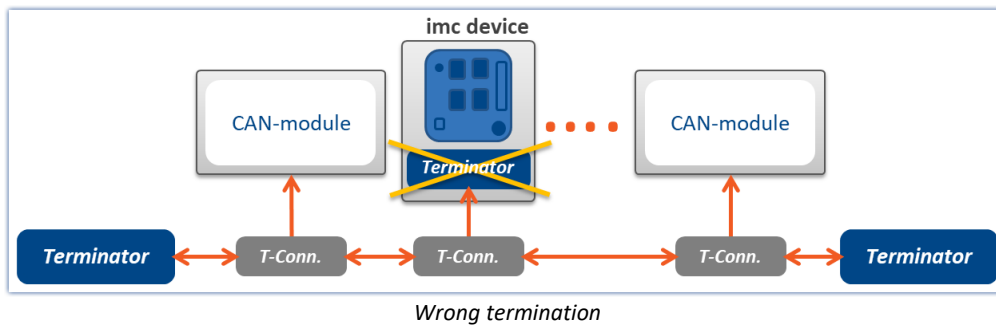

CAN transfer rate

With the transfer rate, it is necessary to distinguish between standard CAN and CAN FD (CAN with flexible data rate). The following description pertains primarily to the classic, standard CAN-Bus.

As signal lead lines become longer, the maximum reliable data transfer rate decreases.

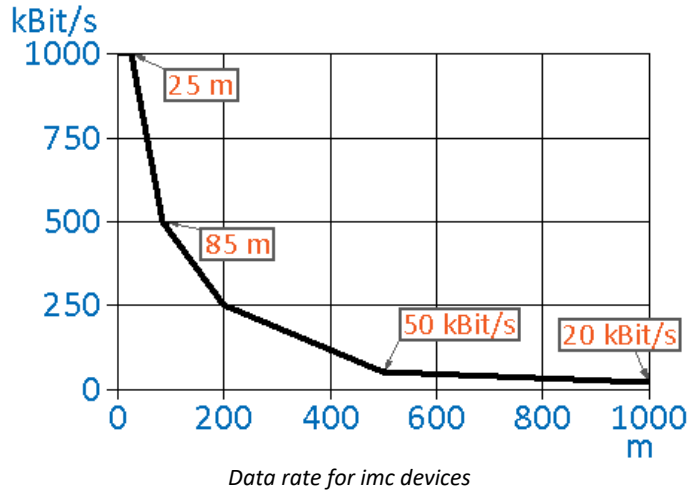

Line length [m]	Data rate [kbit/s]	
3	8000	CAN FD
5	5000	CAN FD
12,5	2000	CAN FD
25	1000	
85	500	
200	250	
500	50	
1000	20	

Net data transmission rate

Conversely, the net data rate depends on the package size and on whether the Standard Frame or the Extended Frame is used.

A high net data rate is achieved by using the maximum number of data bytes for each message. If each message in the **CAN standard** is optimally filled with **8 bytes** and the standard frame is used, the result is **576.6 kbit/s**.

The table shows the net data rates for **CAN standard** 1 Mbit/s.

Data length	Net data rate with CAN-standard 1Mbit/s	
	Standard Frame	Extended Frame
0	-	-
1	72,1 kbit/s	61,1 kbit/s
2	144,1 kbit/s	122,1 kbit/s
3	216,2 kbit/s	183,2 kbit/s
4	288,3 kbit/s	244,3 kbit/s
5	360,4 kbit/s	305,3 kbit/s
6	432,4 kbit/s	366,4 kbit/s
7	504,5 kbit/s	427,5 kbit/s
8	576,6 kbit/s	488,5 kbit/s

With **CAN FD**, even **without** the faster data transmission in the data phase, the larger data volume alone provides considerable advantages. At a nominal bit rate of **1 Mbit/s**, the net data transmission rate for a CAN FD frame with a data length of **64 bytes** is **903 kbit/s**.

9 Technical Specs

All devices described in this manual are intended at least for normal ambient conditions according to IEC 61010-1.

The technical data refer to the reference conditions, such as the specified preferred position of use according to the data sheet, the AC/DC power adaptor: ACC/AC-ADAP-24-60-0B (24 V, 60 W), an ambient temperature of 25 °C as well as compliance with the specifications for use (see chapter "[Precautions for operation](#)"¹⁶). A confidence interval of 95% applies to the min/max specification of the measurement uncertainty.

Electromagnetic Compatibility (EMC) requirements are met according to EN IEC 61326-1 for industrial environments. If the test leads do not provide adequate shielding, performance criterion A is applied for a measurement uncertainty of 2 %. This applies e.g. for device variants with BNC sockets where the shield of the coaxial cable is also the negative connection of the signal. If significant RF interference is to be expected in the measuring environment and the limited accuracy is insufficient, additional shielding measures are required.

The technical data in this section of the manual corresponds to the separate [data sheets](#). In addition to the tables, these also contain photos of the modules, drawings with dimensions and a list of the supplied and optional accessories with the corresponding article numbers. In individual cases, a new data sheet may be published that is not yet included in the manual.

9.1 Operating conditions of the measurement modules

Unless otherwise stated, the following technical data apply to the ARGFT measuring modules:

Operating conditions		
Parameter	Value	Remarks
Operating environment	dry, non corrosive environment within specified operating temperature range	
Ingress protection class	IP50	with correctly fixed and mounted covers ¹⁶ over the module connectors.
Pollution degree	2	
Operating temperature range	-40 °C to +85 °C	standard version: without condensation "-EC" version: temporary condensation allowed
Operating altitude	up to 2000 m	according IEC 61010-1
Rel. humidity	80% up to 31°C, above 31°C: linear declining to 50%	according IEC 61010-1
Shock- and vibration resistance	IEC 60068-2, IEC 61373 IEC 60062-2-64 category 1, class A and B MIL-STD-810 Rail Cargo Vibration Exposure U.S. Highway Truck Vibration Exposure	

Pass through power limits for directly connected modules (click-mechanism)		
Parameter	Value	Remarks
Max. current	5 A	at 85 °C current rating of click connector to ARGFT modules
	60 W at 12 V DC 120 W at 24 V DC	typ. DC vehicle voltage AC/DC power adaptor and installations

9.2 Base unit - Technical Specs

Terminal connections		
Parameter	Value	Remarks
PC / network Ethernet TCP/IP ("LAN")	RJ-45 1000BASE-TX (1 GBit/s) 100BASE-TX (100 MBit/s)	PC/network, synchronization fix and dynamic IP address protocol: IPv4
Flash storage ("microSD")	microSD slot	with protection cap
Internal WLAN adaptor	2 antennas IEEE 802.11g/n/ac Dual Band (2.4 / 5 GHz)	only with ARGFT-BASE-WLAN ¹ (article no. 11400233, "in preparation")
Synchronization ("SYNC")	SMB	IRIG-B, isolated
External GPS module ("GPS")	LEMO.0B (7-pin)	GPS receiver available as accessory
Remote control ("REMOTE")	LEMO.0B (6-pin)	remote power on/off
Power ("PWR")	LEMO.0B (2-pin)	compatible to LEMO.EGE.0B.302 recommended plug FGG.0B.302
imc CANSASfit Interface ("CANSAS")	LEMO.0B (5-pin)	connection of distributed imc CANSASfit modules: Power supply provided by base unit (Power-via-CAN, max. 1 A)
Module connector	Click connection (with covering caps)	mechanical connection, common DC power supply, system bus for imc ARGUSfit modules, interface for imc CANSASfit modules
Power supply		
Parameter	Value	Remarks
Input supply voltage	10 V to 50 V DC	
Power-on threshold (typ.)	≥9.5 V	min. input voltage required for power-on (no load)
Shutdown threshold (typ.)	≤8.5 V	input voltage at which the automatic shutdown is triggered (microSD data backup secured by internal buffering)
Power consumption	3.3 W (typ.) 3.1 W (typ.) @ 12 V DC 3.6 W (typ.) @ 48 V DC	plus 2 % / 10 K
Isolation	±60 V	to case (CHASSIS), isolation impedance ≥1 MΩ
AC/DC power adaptor	110 V to 230 V AC	external adaptor 24 V / 60 W included in delivery

¹ Official Admission certified for Japan, US, Canada, China, Taiwan, Korea

Max. number of modules for direct coupling (block size with click mechanism)		
Parameter	Value	Remarks
Compatible modules	imc ARGUSfit (ARGFT) imc CANSASfit (CANFT)	simultaneous operation of imc ARGUSfit and imc CANSASfit modules supported
Max. number of modules	max. n ARGFT modules + max. 8 CANFT modules	analog and fieldbus interface modules; n modules see Excel power configurator
Pass through power limits for directly connected modules (click mechanism)		
Parameter	Value	Remarks
Max. current	5 A 60 W at 12 V DC 120 W at 24 V DC	at 55 °C current rating of click connector to ARGFT and CANFT modules typ. DC vehicle voltage AC/DC power adaptor or installations
Power delivered by ARGUS Base and fed out to CANFT Interface (Power-via-CAN via LEMO.0B, "CANSAS")		
Max. current	1 A 12 W at 12 V DC 24 W at 24 V DC	at 55 °C, overload and short-circuit protected As long as the base unit is connected to a DC supply voltage, the CANFT modules are permanently supplied via the CANSAS socket regardless of the operating state (on/off) of the base unit. typ. DC vehicle voltage AC/DC power adaptor or installations
Total supply power fed in at the ARGUS Base (via LEMO.0B, "POWER")		
Max. current	5 A 60 W at 12 V DC 120 W at 24 V DC	at 55 °C current load capacity of the LEMO and internal elements. Total power of ARGFT Base and docked ARGFT and CANFT modules and the CANFT-Interface "CANSAS" with Power-via-CAN typ. DC vehicle voltage AC/DC power adaptor or installations
UPS and Data integrity		
Parameter	Value	Remarks
Autarkic operation	✓	Stand-alone data acquisition operation (Auto-start) without PC connection required
Auto data-saving upon power outage	✓	internal power buffering (UPS) to ensure data integrity with "auto-stop" auto-stop of measurement, data storage and automatic shutdown
UPS	integrated	Super-Caps
Charging time of the Super-Caps	approx. 60 s	minimum required active operation for full UPS functionality
UPS coverage	ARGFT base unit	no buffering of directly connected modules
UPS delay	0 s	"buffer-time constant": required duration of a continuous outage that will trigger auto shutdown procedure fixed parameter: cannot be changed in the device configuration!

Storage, signal processing		
Parameter	Value	Remarks
Removable flash storage	microSD	recommended media available at imc; the specified operating temperature range of the media is relevant; Only microSD memory cards tested by imc should be used, otherwise performance or data integrity may be degraded.
Typ. supported transfer rates (write) to microSD	10 channels at 500 kHz 50 channels at 100 kHz	guaranteed with imc qualified media (256 GB), only. Test conditions: data transfer to PC not activated, no additional OFA channels
Interval memory mode	✓	cyclical termination of the measurement data on mass storage medium
Extensive real-time analysis functions	✓	imc Online FAMOS included in standard delivery
Data acquisition, trigger		
Parameter	Value	Remarks
Max. aggregate sampling rate	5 MS/s	sum of sampling rates of all active channels
Channel individual sampling rates	selectable in 1–2–5 steps	max. 500 kS/s, depending on ARGFT module
Number of sampling rates measurement channels	arbitrary	can be used for all hardware-bound channels, such as analogue channels, simultaneously in one configuration
Number of sampling rates fieldbus channels	arbitrary	
Number of sampling rates virtual channels	arbitrary	further rates generated by imc Online FAMOS (e.g. by means of reduction)
Intelligent trigger functions	✓	logical combination of multiple channel events (threshold, transition) to create triggers that start and stop acquisition of assigned channels
Multi triggered data acquisition re-arming time	✓ typ. 30 ms	Multi-shot (with automatic re-arming of the measuring system). depending on system load
Multi trigger	max. 8	independent trigger definitions with arbitrary channel assignments (start/stop)
Trigger definitions	as logical AND/OR combinations of events	events: threshold value, edge, range
Number of event calculations	analog: 1 per module fieldbus: 8 per module	
Number of events used	8 per trigger definition 64 used per device	

Maximum channel count per device		
Parameter	Value	Remarks
Active channels within a systems...	1000	active channels of the current configuration: Total number of analog, fieldbus and virtual channels, as well as monitor channels, if any.
...of which active analog channels	1000	active analog channels of the current configuration (sum of primary channels + monitor channels)
For fieldbus log channels	any number of channels	log channels: non-decoded CAN traffic ("dump")
Monitor channels		
Parameter	Value	Remarks
Monitor channels	for all channels of the type: analog	derived from primary channel with pre-processing function, (processed on the amplifier modules, independent of imc Online FAMOS)
Pre-processing for Monitor channels	reduction AAF RMS Minimum Maximum	each with a reduction factor or block size R selection 1 out of n: resampling resampling with adapted low pass filter RMS over block size R statistics over block size R
Reduction factor R	2 .. 10.000.000 individually selectable	block size or resampling for the processing functions

Synchronization and time base: single device without external synchronization				
Parameter	Value (typ.)	min. / max.	Remarks	
Accuracy RTC		±50 ppm	at 25 °C	
Drift	±20 ppm	±50 ppm	-15 °C to +55 °C operating temperature	
Ageing		±10 ppm	at 25 °C; 10 years	
External synchronization				
Parameter	GPS	IRIG-B	NTP	PTP (in preparation)
Supported formats	NMEA / PPS ⁽¹⁾	B002, B006	Version ≤4	Version 2
Precision	<1 μs		<5 ms after approx. 12 h ⁽²⁾	<1 μs
Jitter (rms) ⁽³⁾	<100 ns		---	<100 ns after 120 s
Voltage level	TTL (PPS ⁽¹⁾) RS232 (NMEA)	5 V TTL level		
Input connection	LEMO.0B (7-pin)	SMB "SYNC" (isolated)	RJ45 "LAN"	RJ45 "LAN"
Synchronization via multiple devices with IRIG-B (Master/Slave)				
Parameter	Value (typ.)	min. / max.	Remarks	
Common mode SYNC isolated		max. 50 V	SMB socket: isolated; for reliable operation even with different common mode level (ground loops)	
Input impedance		20 kΩ		

1 PPS (Pulse per second): signal with an impulse >5 ms is necessary; current max.= 220 mA

2 Initial synchronization

3 Mean statistical variation. Also dependent on signal quality with IRIG-B (e.g. direct connection to imc master device) respectively the specific network configuration with PTP (e.g. point-to-point connection via PTP-capable network switch such as imc NET-SWITCH-5).

9.3 B-4 - Technical Specs

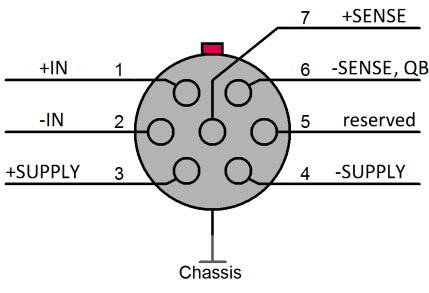

General

Inputs, measurement modes		
Parameter	Value	Remarks
Inputs	4	
Measurement modes	voltage full-, half- and quarter bridge	with internal half- and quarter bridge completion
Connector / socket Measuring input LEMO pin configuration	compatible socket LEMO.1B.307 (7-pin)	recommended plug FEG.1B.307
Module connector	 <p>Click-connection (covering caps)</p>	For the supply and system bus of directly connected modules without further cables, see data sheet of ARGFT base unit.

Sampling rate, Bandwidth, Filter			
Parameter	Value typ.	min. / max.	Remarks
Sampling rate		≤100 kHz	configurable, individually per channel
Bandwidth	0 Hz to 40 kHz 0 Hz to 20 kHz		sampling rate 100 kHz, AAF filter -3 dB 0.1 dB
Filter Type Characteristic Cut-off frequency Order Anti-Aliasing Filter (AAF)	low pass Mean, Butterworth, Bessel, AAF 1 Hz to 20 kHz 8 th order Cauer 8 th order		individual selectable; mean and AAF: adapted automatically, according to selected output rate -3 dB, 1 - 2 - 5 steps digital filter in addition to hardware filter with $f_{\text{cut-off}} = 0.4 f_s$; f_s : output rate
Resolution	24 Bit		data output: 32 Bit Float (24 Bit mantissa)

Isolation		
Parameter	Value	Remarks
Isolation	galvanically isolated	
channel-to-case (CHASSIS)	±60 V	test voltage: ±300 V (10 s)
channel to power supply	±60 V	test voltage: ±300 V (10 s)
channel-to-channel	±60 V	test voltage: ±300 V (10 s)

Power supply of the module			
Parameter	Value typ.	min. / max.	Remarks
Input supply voltage		7 V to 50 V DC 9.5 V to 50 V DC	operating upon power up power supply via base unit, fiber converter or UPS module
Power consumption	2 W @ 12 V 3 W @ 12 V	<7 W	sensor supply not loaded sensor supply loaded
Isolation		±60 V	to case (CHASSIS), isolation impedance ≥1 MΩ

LED		
Parameter	Value	Remarks
Power-LED green	 power active	
Status-LED green blue magenta yellow red	 multicolor operating, run init, etc. firmware update prepare configuration error	global status of module
Channel-Status-LED off green red	bicolor channel passive channel active over-range error	status for each channel >5% over nominal range

Sensor supply			
Parameter	Value typ.	min. / max.	Remarks
Output voltage	15 V, 12 V, 10 V, 7,5 V, 5 V, 4 V, 3.5 V, 3.3 V, 3 V, 2.5 V		referenced to -SUPPLY, arbitrary for each channel
Short-Circuit-Proof		unlimited time	protection for module and each channel
Error of output voltage		±3% 0.01%/K·ΔT _a	ΔT _a = T _a - 25°C , with T _a = ambient temperature
Max. output current	150 mA		
Output power per channel		0.5 W	depending on output current limit
Capacitive load	0 to 1000 μF		
Output impedance	0.5 Ω		

Measurement modes

Voltage measurement			
Parameter	Value typ.	min. / max.	Remarks
Input ranges	±10 V, ±5 V, ±2.5 V, ±1 V to ±25 mV		
Max. over voltage	±60 V		
Input coupling	DC		
Input impedance	1 GΩ		
Gain error		0.02% + 0.001%/K·ΔT _a	of the measured value ΔT _a = T _a - 25°C , with T _a = ambient temperature
Offset error		0.02% or 10 μV + 0.001%/K·ΔT _a	of input range whichever is greater ΔT _a = T _a - 25°C , with T _a = ambient temperature
Nonlinearity	6 ppm		
Isolation mode rejection ratio (IMRR)	120 dB		50 Hz
Signal-to-Noise Ratio (SNR)	107 dB 107 dB 107 dB 105 dB 104 dB 103 dB 98 dB 93 dB 87 dB		bandwidth = 1 kHz; input ranges: 10 V 5 V 2.5 V 1 V 500 mV 250 mV 100 mV 50 mV 25 mV

Bridge measurement			
Parameter	Value typ.	min. / max.	Remarks
Input ranges	±1000 mV/V, ±500 mV/V, ±250 mV/V,..., ±500 mV/V, ±250 mV/V, ±100 mV/V,..., ±25 mV/V,..., ±2.5 mV/V ±5 mV/V ±10 mV/V ±25 mV/V		full bridge half bridge quarter bridge for excitation voltage ($V_{excitation}$): 5 V 2.5 V 1 V 0.5 V
Max. over voltage		±60 V	
Input coupling		DC	
Input impedance ±IN ±SENSE	1 GΩ 10 MΩ		
Gain error		0.03% + 0.05% + 0.05% + 0.001%/K·ΔT _a	of the measured value full and half bridge input ranges ≥ 5 mV/V input range = 2.5 mV/V quarter bridge, all ranges ΔT _a = T _a - 25°C , with T _a = ambient temperature
Offset error ¹		0.03% + ± 7 μV/V/K·ΔT _a 0.03% + ± 0.4 μV/V/K·ΔT _a 0.05% + ± 0.1 μV/V/K·ΔT _a	full and half bridge, of input range 1000 mV/V, ..., 100 mV/V 50 mV/V, ..., 10 mV/V 5 mV/V, ..., 2.5 mV/V ΔT _a = T _a - 25°C , with T _a = ambient temperature
Nonlinearity	6 ppm		

1 After a bridge balancing process, the offset is nearly zero.

Bridge measurement			
Parameter	Value typ.	min. / max.	Remarks
Excitation voltage	5 V, 2.5 V, 1 V, 0.5 V	±0.05%	This tolerance must not be added when calculating total uncertainty. It is fully compensated due to the factory adjustment.
Load regulation range (Compensation of cable resistance by using ±SENSE)	90% to 100%		of excitation voltage $R_{\text{bridge}} / (R_{\text{bridge}} + R_{\text{cable}})$
Load regulation	-0.07 ppm/Ω·R _{cable}		additional gain error: compensation of cable resistance by using ±SENSE-inputs
Bridge resistance	100 Ω to 10 kΩ		
Half bridge completion		0.0005%/K·ΔT _a	ΔT _a = T _a - 25°C , with T _a = ambient temperature
Quarter bridge completion	1 kΩ, 350 Ω, 120 Ω	±0.1% +	This tolerance must not be added when calculating total uncertainty. It is fully compensated due to the factory adjustment as well as the bridge balancing process.
Drift		0.0005%/K·ΔT _a	ΔT _a = T _a - 25°C , with T _a = ambient temperature
Shunt calibration resistors (integrity check for entire signal chain)	499.5 kΩ, 174.83 kΩ, 59.94 kΩ	±0.12%	R _{bridge} : 1 kΩ 350 Ω 120 Ω
Isolation mode rejection ratio (IMRR)	150 dB		50 Hz, full bridge
Signal-to-Noise Ratio (SNR) ²	107 dB 107 dB 106 dB 104 dB 103 dB 99 dB 92 dB 87 dB 81 dB		bandwidth = 1 kHz, V _{excitation} = 5 V, full bridge, 120 Ω, input ranges: ±1000 mV/V ±500 mV/V ±250 mV/V ±100 mV/V ±50 mV/V ±25 mV/V ±10 mV/V ±5 mV/V ±2.5 mV/V

2 Add a value of 20 dB · log (V_{excitation}/5 V) for bridge excitation voltages different to 5 V.

 Reference

Please find [here the description of the B-4](#) ^[64] and technical specs of [environmental conditions here](#) ^[80].

9.4 UTI-6 - Technical Specs

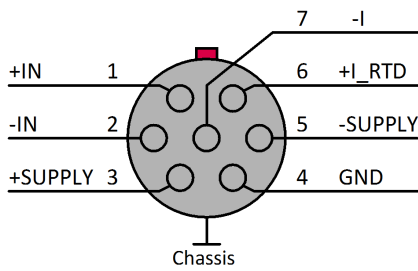

General

Inputs, measurement mode			
Parameter	Value typ.	min. / max.	Remarks
Inputs		6	
Measurement mode	voltage current resistance temperature PT100/PT1000		4-wire
Connector / socket Measuring input LEMO pin configuration	compatible socket type LEMO.1B 7-pin measuring input		recommended plug FEG.1B.307
Module connector			for the supply and system bus of directly connected modules without further cables, see data sheet of ARGFT base unit
	Click-connection (covering caps)		

Sampling rate, Bandwidth, Filter			
Parameter	Value typ.	min. / max.	Remarks
Sampling rate		≤100 kHz	configurable, individually per channel
Bandwidth	0 Hz to 40 kHz 0 Hz to 30 kHz		sampling rate 100 kHz, AAF filter -3 dB 0.1 dB
Filter Type Characteristic Cut-off frequency Order Anti-aliasing filter	low pass Mean, Butterworth, Bessel, AAF 1 Hz to 20 kHz 8 th Cauer 8 th order		individual selectable; mean and AAF: adapted automatically, according to selected output rate -3 dB, 1 - 2 - 5 steps digital filter in addition to hardware filter with $f_{cut-off} = 0.4 \cdot f_s$; f_s : output rate
Resolution	24 Bit		output: 32 Bit Float (24 Bit mantissa)

Isolation		
Parameter	Value	Remarks
Isolation	galvanically isolated	
channel-to-case (CHASSIS)	±60 V	test voltage: ±300 V (10 s)
channel to power supply	±60 V	test voltage: ±300 V (10 s)
channel-to-channel	±60 V	test voltage: ±300 V (10 s)

Power supply of the module			
Parameter	Value typ.	min. / max.	Remarks
Input supply voltage		7 V to 50 V DC 9.5 V to 50 V DC	operating upon power up power supply via base unit, fiber converter or UPS module
Power consumption	3 W 1.5 @ 12 V 5.7 @ 12 V	3 W 7 W	sensor supply not loaded sensor supply loaded
Isolation		±60 V	to case (CHASSIS), isolation impedance ≥1 MΩ

LED		
Parameter	Value	Remarks
Power-LED 	power active	
Status-LED 	multicolor operating, run init, etc. firmware update prepare configuration error	global status of module
Channel-Status-LED	bicolor channel passive channel active over-range error error	status for each channel >5 % over nominal range

Sensor supply			
Parameter	Value typ.	min. / max.	Remarks
Output voltage	$\pm 15\text{ V}, \pm 12\text{ V}, \pm 10\text{ V}, \pm 7.5\text{ V},$ $\pm 5\text{ V}, \pm 4\text{ V}, \pm 3.5\text{ V}, \pm 3.3\text{ V}, \pm 3\text{ V}, \pm 2.5\text{ V}$		referenced to GND; arbitrary for each channel
Short-Circuit-Proof	unlimited duration		protection for module and each channel
Error of output voltage		$\pm 2\%$ $0.01\%/K \cdot \Delta T_a$	$\Delta T_a = T_a - 25^\circ\text{C} $; with T_a = ambient temperature
Max. Output current	150 mA		
Output power			
per channel		0.5 W 0.4 W	bipolar supply with symmetric load unipolar supply or asymmetric load
per module		2 W	
Output impedance	0.6 Ω		

Measurement modes

Voltage measurement			
Parameter	Value typ.	min. / max.	Remarks
Input range	$\pm 60\text{ V}, \pm 50\text{ V}, \pm 25\text{ V}, \pm 10\text{ V}, \pm 5\text{ V},$ $\pm 2.5\text{ V}, \pm 1\text{ V to } \pm 25\text{ mV}$		input range $\pm 60\text{ V}$ (nominal working voltage according to low voltage directive SELV) is valid up to 100 V without limitation
Max. Over Voltage	$\pm 200\text{ V}$		differential input voltage
Input coupling	DC		
Input impedance	1 M Ω 20 M Ω	$\pm 1\%$ $\pm 1\%$	measurement ranges $\geq \pm 5\text{ V}$ or device off measurement ranges $\leq \pm 2.5\text{ V}$
Gain error	0.008% $+ 0.0004\%/K \cdot \Delta T_a$	0.02% $+ 0.001\%/K \cdot \Delta T_a$	of reading $\Delta T_a = T_a - 25^\circ\text{C} $; with T_a = ambient temperature
Offset error	0.003% $+ 0.00006\%/K \cdot \Delta T_a$	0.02% or 10 μV $+ 0.001\%/K \cdot \Delta T_a$	of range whichever is greater $\Delta T_a = T_a - 25^\circ\text{C} $; with T_a = ambient temperature
Bandwidth			
ranges $\pm 60\text{ V to } \pm 100\text{ mV}$	0 Hz to 40 kHz 0 Hz to 30 kHz		-3 dB 0.1 dB
ranges $\pm 50\text{ mV to } \pm 25\text{ mV}$	0 Hz to 30 kHz 0 Hz to 8 kHz		-3 dB 0.1 dB
IMRR (Isolation mode rejection ratio)	90 dB 130 dB		50 Hz measurement ranges $\geq \pm 5\text{ V}$ measurement ranges $\leq \pm 2.5\text{ V}$
Noise	1 mV _{rms} 16 μV _{rms} 14 μV _{rms}		sampling rate = 100 kHz; filter = AAF; resolution = 32 bit float; ranges: 60 V, ..., 5 V 2.5 V 1 V, ..., 25 mV

Current measurement			
Parameter	Value typ.	min. / max.	Remarks
Input range	±20 mA		
Overload	±100 mA		
Input coupling	DC		
Input impedance	25 Ω	±1%	
Gain error		0.02% + 0.002%/K·ΔT _a	of the measured value ΔT _a = T _a -25°C ; with T _a = ambient temperature
Offset error		0.01% + 4 nA/K·ΔT _a	of range ΔT _a = T _a -25°C ; with T _a = ambient temperature
Bandwidth	0 Hz to 48 kHz 0 Hz to 30 kHz		-3 dB 0.1 dB

Resistance measurement			
Parameter	Value typ.	min. / max.	Remarks
Input range	100 kΩ, 50 kΩ, 25 kΩ, 10 kΩ, ..., 100 Ω		
Overvoltage protection	±30 V		
Input coupling	DC		
Gain error		0.02% + 0.002%/K·ΔT _a	of the measured value ΔT _a = T _a -25°C ; with T _a = ambient temperature
Offset error		0.01% + 0.003%/K·ΔT _a	of range ΔT _a = T _a -25°C ; with T _a = ambient temperature
Bandwidth	0 Hz to 28 kHz 0 Hz to 10 kHz		-3 dB 0.1 dB

RTD measurement			
Parameter	Value typ.	min. / max.	Remarks
Temperature Sensors	Resistance Temperature Detectors (RTDs) PT100, PT1000		4-wire configuration
Input range	-200°C to 850°C -200°C to 250°C		
Overvoltage protection	±60 V		
Input coupling	DC		
Supply Current	0.88 mA 0.7 mA		PT100; P _{dis} < 0.3 mW PT1000; P _{dis} < 1.9 mW
Measurement error PT100, PT1000			
-200°C to 0°C	0.001 K	0.05 K	
0°C to 100°C	0.001 K	0.1 K	
100°C to 300°C	0.002 K	0.18 K	
300°C to 500°C	0.003 K	0.25 K	
500°C to 850°C	0.006 K	0.4 K	

 Reference

Please find [here the description of the UTI-6](#)^[70] and technical specs of [environmental conditions here](#)^[80].

9.5 ICPU-6 - Technical Specs



General

Inputs, measurement modes		
Parameter	Value	Remarks
Inputs	6	differential, analog
Measurement modes	voltage measurement IEPE / ICP (Integrated Electronics Piezo Electric)	
Supported sensors	IEPE / ICP	
TEDS (Transducer Electronic Data Sheet)	supported on the hardware side Software support (imc STUDIO): in preparation	
Connector / socket Measuring input Module connector	BNC Click-connection (with covering caps)	for the supply and system bus of directly connected modules without further cables, see data sheet of the ARGFT base unit

Sampling rate, bandwidth, filter			
Parameter	Value typ.	min. / max.	Remarks
Sampling rate		≤500 kHz	individually selectable per channel
Bandwidth	0 Hz to 220 kHz 0 Hz to 200 kHz		-3 dB 0.1 dB
Filter Type Characteristic Cut-off frequency Order Anti-aliasing filter	low pass Mean, Butterworth, Bessel, AAF 10 Hz to 50 kHz 8 th Cauer 8 th order with $f_{\text{cut-off}} = 0.4 f_s$		individually selectable; mean and AAF: adapted automatically, according to selected output rate -3 dB, 1 - 2 - 5 steps digital filter in addition to hardware filter f_s : output rate
Resolution	24 bit		data output: 32 bit Float (24 bit mantissa)

Isolation		
Parameter	Value	Remarks
Isolation channel-to-case (CHASSIS) channel to power supply channel-to-channel	galvanically isolated ±60 V ±60 V ±60 V	test voltage: ±300 V (10 s) test voltage: ±300 V (10 s) test voltage: ±300 V (10 s)

Power supply of the module			
Parameter	Value typ.	min. / max.	Remarks
Input supply voltage		7 V to 50 V DC 9.5 V to 50 V DC	operating upon power up power supply via base unit, fiber converter or UPS module
Power consumption		4 W / 5 W (min.)/(max.)	plus up to 1 W for sensor supply, plus 2 %/10 K
Isolation		±60 V	to case (CHASSIS), isolation impedance ≥1 MΩ

Status-LED		
Parameter	Value	Remarks
Power-LED green	 power active	
Status-LED green blue magenta yellow red	 multicolor OK init, etc. firmware update prepare configuration error	global status of module
Channel-Status-LED off green red	channel passive channel active no sensor, short circuit	status for each channel error (in case of overload, no IEPE sensor connected or short-circuit of sensor)

Measurement modes

DC voltage measurement				
Parameter	Value typ.		min. / max.	Remarks
Input ranges	±60 V, ±50 V, ±25 V, ±10 V, ±5 V, ... to ±25 mV			input range ±60 V (nominal working voltage according to low voltage directive SELV) is valid up to 100 V without limitation
Max. overvoltage			±200 V	
Input coupling			DC	
Input impedance	1.3 MΩ 10 MΩ	±1% ±2%		input range >±10 V input range ≤±10 V
Gain error			0.02% + 0.003%/K·ΔT _a	of the reading ΔT _a = T _a -25°C ; with T _a = ambient temperature
Offset error			0.02% + 0.002%/K·ΔT _a 25 μV + 2μV/K·ΔT _a	of the input range input range >±100 mV ΔT _a = T _a -25°C ; with T _a = ambient temperature input range ≤±100 mV ΔT _a = T _a -25°C ; with T _a = ambient temperature
Signal-to-Noise Ratio typ. SNR	band width 0.1 Hz ... 220 kHz	band width 0.1 Hz ... 20 kHz	band width 0.1 Hz... 1 kHz	range: 91 dB 102 dB 113 dB 60 V 93 dB 104 dB 116 dB 50 V 88 dB 99 dB 111 dB 25 V 98 dB 110 dB 121 dB 10 V 99 dB 110 dB 120 dB 5 V 98 dB 107 dB 120 dB 2.5 V 98 dB 112 dB 119 dB 1 V 97 dB 108 dB 118 dB 500 mV 94 dB 104 dB 115 dB 250 mV 86 dB 98 dB 109 dB 100 mV 80 dB 92 dB 103 dB 50 mV 74 dB 86 dB 97 dB 25 mV

AC voltage measurement				
Parameter	Value typ.		min. / max.	Remarks
Input ranges	±60 V, ±50 V, ±25 V, ±10 V, ±5 V, ... to ±25 mV			input range ±60 V (nominal working voltage according to low voltage directive SELV) is valid up to 100 V without limitation
Max. overvoltage			±200 V	
Input coupling	AC			
cut-off frequency	1 Hz		±8%	-3 dB; 0.1% settling time approx. 3 s
Max. Signal (AC + DC)	±60 V ±12 V			range: >10 V ≤10 V
Input impedance	1.3 MΩ 10 MΩ		±1% ±2%	input range >±10 V input range ≤±10 V
Gain error			0.05% + 0.003%/K·ΔT _a	of the reading ΔT _a = T _a -25°C ; with T _a = ambient temperature
Signal-to-Noise Ratio typ. SNR	band width 0.1 Hz ... 220 kHz	A- weighted	band width 0.1 Hz... 1 kHz	range:
	91 dB	102 dB	113 dB	60 V
	93 dB	104 dB	116 dB	50 V
	88 dB	99 dB	111 dB	25 V
	98 dB	110 dB	121 dB	10 V
	99 dB	110 dB	122 dB	5 V
	98 dB	107 dB	120 dB	2.5 V
	98 dB	112 dB	119 dB	1 V
	97 dB	108 dB	118 dB	500 mV
	94 dB	104 dB	114 dB	250 mV
	86 dB	98 dB	106 dB	100 mV
	80 dB	92 dB	100 dB	50 mV
	74 dB	86 dB	94 dB	25 mV

IEPE measurement				
Parameter	Value typ.		min. / max.	Remarks
Input ranges	±10 V, ±5 V, ±2,5 V, ±1 V, ... to ±25 mV			
Max. overvoltage			±200 V	
Input coupling			IEPE	
cut-off frequency	1 Hz		±8%	-3 dB; 0.1% settling time approx. 3 s
Input impedance	0.8 MΩ			
Gain error			0.05% + 0.003%/K·ΔT _a	of the reading ΔT _a = T _a - 25°C ; with T _a = ambient temperature
Signal-to-Noise Ratio typ. SNR	band width 0.1 Hz ... 220 kHz	A- weighted	band width 0.1 Hz... 1 kHz	range:
	98 dB	110 dB	112 dB	10 V
	97 dB	109 dB	110 dB	5 V
	95 dB	107 dB	109 dB	2.5 V
	88 dB	105 dB	108 dB	1 V
	82 dB	101 dB	103 dB	500 mV
	76 dB	96 dB	97 dB	250 mV
	68 dB	88 dB	89 dB	100 mV
	62 dB	82 dB	83 dB	50 mV
56 dB	76 dB	77 dB	25 mV	

Sensor supply			
Parameter	Value typ.	min. / max.	Remarks
IEPE constant current source	4.2 mA	±5%	
Output voltage	+20.2 V to 1.8 V	+20 V to 2 V	
'Short circuit' detection	1.8 V	<1.4 V	sensor voltage
'Non sensor' detection	20.4 V	>22 V or <2 mA	sensor current
Max. Overvoltage			±200 V



 Reference

Please find [here the description of the ICPU-6](#)^[75] and technical specs of [environmental conditions here](#)^[80].

9.6 Expansions



9.6.1 Fiber Converter - Technical Specs

Terminal connections		
Parameter	Value	Remarks
Power supply "POWER"	LEMO.0B (2-pin)	compatible to LEMO.EGE.0B.302 suitable plug FGG.0B.302
Module connector	Click connection (with covering caps)	mechanical connection, common DC power supply, system bus for imc ARGUSfit modules
Optical LC duplex connector cable length	Laser class 1 max. 250 m	fiber optic cable OM3 Multimode
Power supply		
Parameter	Value	Remarks
Input supply voltage	10 V to 50 V DC	
Power-on threshold (typ.)	>12.5 V	min. input voltage required for power-on (open circuit)
Shutdown threshold (typ.)	<8 V	input voltage at which the automatic deactivation is triggered
Power consumption	0.5 W 0.6 W 0.9 W 0.1 W 0.2 W 0.3 W	typical value without connected modules module active: at 12 V DC at 24 V DC at 48 V DC module in sleep mode: at 12 V DC at 24 V DC at 48 V DC
Isolation	±60 V	to case (CHASSIS), isolation impedance ≥1 MΩ
AC/DC power adaptor	110 V to 230 V AC	external adaptor 24 V / 60 W included in delivery
Max. number of modules for direct coupling (block size with click mechanism)		
Parameter	Value	Remarks
Compatible modules	imc ARGUSfit (ARGFT)	right and left not clickable at the same time; Master/slave function is automatically detected
Max. number of modules	max. n ARGFT modules	analog and digital modules, fieldbus module; n modules see Excel power configurator
Wake-up duration from sleep mode	≤1 s	after signal activity at the optical port the slave switches on the right clicked modules
Pass through power limits for directly connected modules (click mechanism)		
Parameter	Value	Remarks
Max. current	5 A 60 W at 12 V DC 120 W at 24 V DC	typ. DC vehicle voltage AC/DC power adaptor or installations

Status- & Power LED		
Parameter	Wert	Bemerkungen
Power-LED  green red	bicolor actively powered TBD	
Status-LED  red green yellow blue blue flashing	multicolor error ready for measurement warning error sleep mode	module connected right and left at the Fiber-Converter module connected right or left and signal activity optical receive level low (e.g. increased cable attenuation) no module clicked at the fiber converter sleep mode

Operating conditions ARGFT/FIBER-CONVERTER		
Parameter	Value	Remarks
Operating temperature range	-40 °C to +85 °C	standard version: without condensation no "-EC" version available

References

- Please find here all further technical specs of [environmental conditions](#)  ⁸⁰.
- Please find a detailed description of the Fiber-Converter in chapter "[Assembly and connection](#)"  ²¹".

9.6.2 UPS-NiMH - Technical Specs

Power supply		
Parameter	Value	Remarks
Input supply voltage	10 V to 50 V DC	e.g. via AC/DC adapter or vehicle power supply via LEMO supply socket "Power In"
Power-on threshold (typ.)	10 V DC	min. input voltage required for power-on (open circuit)
UPS take-over threshold (typ.)	9.3 V DC 9.9 V DC	at 25 °C, no load take-over internal buffer battery switch back to external supply
Input power	60 W	max.
Output voltage	$V_{in} - 0.4$ V DC (min.) 12 V DC (typ.)	10 V to 50 V DC input (full load), "Power Out" buffer operation
Output power	50 W	at normal conditions according EN 61010-1
Tolerated overload	shutdown after: 10 s 1 s	with static load > 50 W in operation with external supply in buffer operation
Overload / short-circuit protection Output	long-term (reversible)	with power ground of the output voltage; repeated automatic restart until error condition has been resolved
Overload protection Input	safety fuse 10 A	

Uninterruptible power supply (UPS)			
Parameter	Value typ.	min. / max.	Remarks
Battery type	NiMH		
Nominal capacity		12 Wh	25 °C, fully charged battery
Available buffer capacity	11 Wh 6.5 Wh		battery was fully charged at 25 °C 12 W output power, 25 °C 50 W output power, 25 °C
Reduction of the maximum output power for buffer operation in cold conditions	1 W / K		$T_a < +15$ °C, fully charged battery
Continuous buffer duration (bridging time)	30 s		internal timer is reset when external supply is applied
Charging power	8.0 W		module switched on
Charging time ratio: charging- and discharging duration	1.25 · (total power / 8 W)		worst case example: total power of the system: 50 W discharge time 0.5 min., resulting charge time < 4 min. (charging time ratio 8:1)
Charging time for complete battery recovery	2.4 h		module switched on
Temperature range	-10 to +60 °C -10 to +60 °C -20 to +65 °C		charging discharging standby

General		
Parameter	Value	Remarks
Isolation	isolated to case, no input-to-output isolation	to case (CHASSIS)
Power supply sockets	LEMO.0B (2-pin)	recommended plug FGG.0B.302 "POWER IN" and "POWER OUT"
Remote control	LEMO.0B (6-pin)	recommended plug FGG.0B.306 "REMOTE" and "REMOTE OUT"
On/Off push button	✓	
Weight	0.7 kg	
Dimensions (L x W x H)	153 x 69 x 53 mm	including mounting flanges and click mechanism
Status LED	POWER (Tri-Color) LIMIT (Tri-Color) battery charge level (4 segment Tri-Color)	operating mode overload battery charge level and UPS state

Reference

Please find a detailed description of the UPS-NiMH - Technical Specs in chapter "[Assembly and connection](#)"²².

The meaning of the LED indicators of the UPS-NiMH - Technical Specs can be found in the section "[LED display](#)"²⁵.



9.6.3 CAN bus - Technical Specs

Parameter	Value	Remarks
Number of CAN-nodes	2	one galvanically isolated node per connector
Terminal connection	2x DSUB-9	
Topology	bus	
Transfer protocol	configurable per software: CAN FD (ISO Standard) (max. 8 MBaud) non-ISO CAN FD (Draft) (max. 8 MBaud) CAN High Speed (max. 1 MBaud) CAN Low Speed (max. 125 KBaud)	individually for each node current standard according ISO 11898-1:2015 former draft (Bosch) according ISO 11898 according ISO 11519
Operating principle	Multi Master principle	
Direction of data flow	sending and receiving	
Operating mode	decoding channels logging of raw data silent mode / listen only cyclic sequence output	physically and numerically scaled channels log channels in imc TSA format ("Dump") passive, without acknowledge initialization of sensors
Baud rate	5 kbit/s to 8 Mbit/s	configurable via software; maximum is depending on selected protocol (FD/High/Low Speed)
Termination	120 Ω	switchable by software for each node
Direct parameterizing of imc CANSAS modules	via dbc file import	dbc file import to be created with imc CANSAS software. e.g. via USB-CAN interface

Isolation

Parameter	Value	Remarks
Isolation	galvanically isolated	
CAN-to-case (CHASSIS)	±60 V	test voltage: ±300 V (10 s)
CAN-to-power supply	±60 V	test voltage: ±300 V (10 s)
CAN-to-channel	±60 V	test voltage: ±300 V (10 s)

Status-LED

Parameter	Value	Remarks
Power-LED 	power active reverse polarity fault	
Status-LED 	multicolor operating, run init, etc. firmware update prepare configuration error	global status of module
ACT LED	LED flashing at 200 ms rate when messages are received or sent.	

Status-LED		
Parameter	Value	Remarks
TERMI LED green off	CAN termination active CAN termination not active	
PvCAN LED green red off	PvCAN active error e.g. short-circuit PvCAN not active	Power via CAN LED is green when PvCAN voltage has been activated and turns red upon power error or overload.

Power via CAN		
Parameter	Value	Remarks
Output voltage	power supply of CAN FD module which is the supply of the entire ARGUS system	available at node 1, can be switched on via software
Output current	1 A	to supply imc CANSAS modules accuracy of the current limit: $\pm 3\%$
Short circuit protection	unlimited duration	

Power supply of the module			
Parameter	Value typ.	min. / max.	Remarks
Input supply voltage		7 V to 50 V DC 9.5 V to 50 V DC	operating upon power up power supply via base unit, fiber converter or UPS module
Power consumption	3.8 W 4.5 W 6 W		passive (idle) active (data acquisition configuration) power-up phase (with buffer charging)
Power supply options	via adjacent module		module connector (click mechanism)
Isolation	± 60 V		to case (CHASSIS), isolation impedance ≥ 1 M Ω

Operating conditions ARGFT/CAN FD		
Parameter	Value	Remarks
Operating temperature range	-40 °C to +85 °C	for modules as of revision 6 standard version: without condensation "-EC" version: temporary condensation allowed

Reference

Please find here all further technical specs of [environmental conditions](#) .

10 Pin configuration

10.1 Power

The base unit, the fiber converter and the UPS module are all equipped with a "Power" socket on the front in order to supply the connected module block with power.

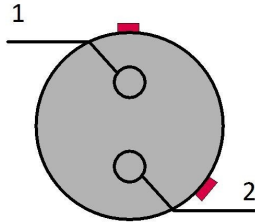

Fig. 42: Socket for the power supply
(view on top of the socket)

PIN	Signal
1	+PWR
2	-PWR

There is a red mark on the side of the positive pole.

10.2 Remote

Both the base unit and the [UPS module](#) ^[22] are equipped with a "remote" socket on the front. Please read the chapter "[UPS-NIMH](#)" ^[22] carefully before using the UPS module.

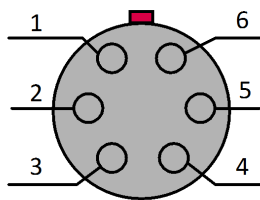

Fig. 43: Remote socket
(view on top of the socket)

PIN	Signal
1	GND
2	remote switch
3	GND
4	remote push button
5	GND *
6	MUTE *

* only in the REMOTE socket of the [UPS module](#) ^[22]

Remote On/Off

Switching on/off the base unit and all [modules connected to the base unit](#) ^[17] can be done via the remote connection in addition to the [on/off button](#) ^[26]. The following functions are available:

! Note

Remote switch (pin 2)

Bridge remote switch (**pin 2**) with GND to switch on/off.

If this connection is **permanently** bridged, the base unit can be switched on or off automatically via the supply voltage. If a self-start configuration has been stored in the unit, it can be used, for example, to automatically start a measurement in the vehicle when the board voltage is switched on.

! Note

Remote push button (pin 4)

Briefly bridge remote push button (**pin 4**) with GND to switch on/off.

10.3 Base Unit

10.3.1 GPS

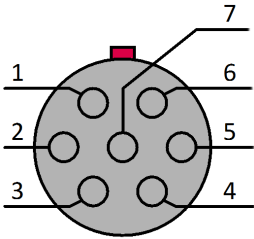

Fig. 44: GPS socket
(base unit)
(view on top of the socket)

PIN	Signal	
1	VCC	4.2 V - 5 V / 300 mA
2	RxD	
3	TxD	
4	CTS	
5	GND	
6	RTS	
7	1 pps	

Reference

[GPS description GPS signals](#) ⁴²

10.3.2 CANSAS

This LEMO socket "CANSAS" (size 0B) on the front of the ARGFT base unit is intended exclusively for imc CANSASfit (CANFT) modules. The ARGFT supply POWER is passed through to supply the CANFT modules (CAN-SUPPLY, max. 1 A). As long as the base unit is connected to a DC supply voltage, the CANFT modules are permanently supplied via the CANSAS socket regardless of the operating state (on/off) of the base unit.

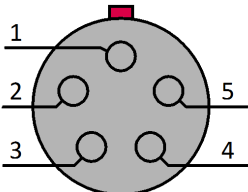

Fig. 45: Socket to connect
CANFT modules
(view on top of the socket)

PIN	Signal
1	+CAN-SUPPLY
2	-CAN-SUPPLY
3	CAN_H
4	CAN_L
5	CAN_GND

Reference

[Description: chapter Assembly and connection](#) ¹⁷

10.4 Measurement Modules

10.4.1 B-4

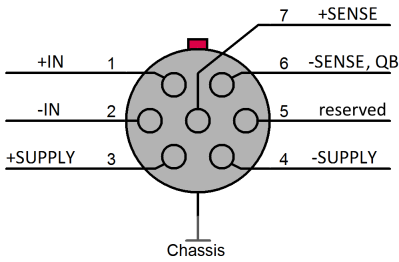



Fig. 46: B-4 socket (pinning)
(View on top of the socket)

 Reference

[Description of the module](#) 

10.4.2 UTI-6

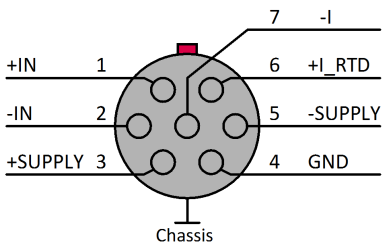



Fig. 47: UTI-6 socket (pinning)
(View on top of the socket)

 Reference

[Description of the module](#) 

10.4.3 ICPU-6

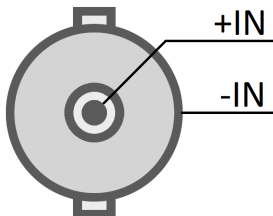



Fig. 48: ICPU-6 socket (pinning)
(view on top of the socket)

 Reference

[Description of the module](#) 

10.4.4 CAN FD (DSUB-9)

DSUB-PIN	Signal		Description	Use in device	
	CAN 1	CAN 2		CAN 1	CAN 2
1	+CAN_SUPPLY	nc	supply only at CAN 1 , PvCAN , $I < 1$ A	connected	do not connect
2	CAN_L		dominant low bus line	connected	
3	CAN_GND		CAN Ground	connected	
4	nc		reserved	do not connect	
5	-CAN_SUPPLY	nc	supply only at CAN 1	connected	do not connect
6	CAN_GND		optional CAN Ground	connected	
7	CAN_H		dominant high bus line	connected	
8	nc		reserved	do not connect	
9	nc		reserved	do not connect	

Notes

- The maximum current of 1 A must not be exceeded at CAN node 1. The CANSAS modules' low power consumption should not be underestimated, since at low supply voltages high power values can accrue from high current. Two UNI8 units with power consumption of approx. 30 W (with connected sensors) already exceed the limit by having a current of 2 A at 15 V. Additional factors are the voltage drop along long wires, and small wire cross-sections. In any case, it is necessary to first calculate the power consumption and the current strengths to be expected.
- The direction of current flow is unidirectional, protected by diodes: the ARGFT CAN FD module supplies CAN bus participants.
- When the ARGFT system is switched off, the power supply "PvCAN" also is switched off.
- The PvCAN supply is equipped with electronic overload and short-circuit protection. This must be reset after a fault (switching the ARGFT/CAN-FD off and on).
- Only one supply may be used at any time. If an external supply is applied to the CAN bus and the ARGFT's power supply unit is additionally connected, Power-via-CAN must be deactivated on the ARGUS device via software.
- Using -CAN_SUPPLY does not replace the CAN_GND connection! CAN_GND must be used independently of the outgoing supply so that the levels of CAN_H and CAN_L are reliably detected (-CAN_SUPPLY is power supply connection, CAN_GND is signal connection).

Reference

[Module description](#)  76

Figures

Figure 1: parking position of covering caps	16
Figure 2: Order of possible Click connections	17
Figure 3: Locking tongue & locking latch	17
Figure 4: locking latch	17
Figure 5: CAN termination	19
Figure 6: Power supply via ARGFT base unit	20
Figure 7: Fiber converter application	21
Figure 8: ARGFT/UPS-NIMH with ARGFT/FIBER-CONVERTER	22
Figure 9: Power supply via ARGFT/UPS-NIMH	23
Figure 10: ARGFT-BASE LEDs	30
Figure 11: Photo of the front of the base unit	39
Figure 12: Dimensions, extra wide XW housing: applies to base unit and UPS	40
Figure 13: Dimensions, narrow standard housing: applies to UTI-6, ICPU-6, Fiber-Converter, CAN FD Interface and the B-4	40
Figure 14: Overview of the sampling theorem with Anti-Aliasing Filter (AAF) of the ARGUS series	45
Figure 15: signal processing chain of the ARGUS series	45
Figure 16: Frequency response of the ARGUS series	46
Figure 17: Filter options of the ARGUS series	46
Figure 18: Comparison of different filter characteristics for low-pass filters ($f_s \text{ prim} = 200 \text{ kSps}$)	47
Figure 19: Comparison of the step response of different filter characteristics	48
Figure 20: "Filter type: AAF" (Cauer) for different cut-off frequencies ($f_s \text{ prim} = 200 \text{ kSps}$)	49
Figure 21: "Filter type: Average filter" for different sampling rates ($f_s \text{ prim} = 200 \text{ kSps}$)	50
Figure 22: "Filter type: Bessel" for different cut-off frequencies f_c ($f_s \text{ prim} = 100 \text{ kSps}$)	51
Figure 23: "Filter type: Butterworth" for different cut-off frequencies f_c ($f_s \text{ prim} = 100 \text{ kSps}$)	52
Figure 24: "Filter type: without" for ARGFT/ICPU-6 at 500 kSps	53
Figure 25: Quarter bridge in two wire configuration	57
Figure 26: Quarter bridge in three wire configuration	57
Figure 27: Connection schematic B-4 quarter bridge	64
Figure 28: Block schematic B-4 quarter bridge	64
Figure 29: Connection schematic B-4 half bridge	65
Figure 30: Block schematic B-4 half bridge	65
Figure 31: Connection schematic B-4 full bridge	65
Figure 32: Block schematic B-4 full bridge	65
Figure 33: 4-wire configuration (B-4)	66
Figure 34: 6-wire configuration (B-4)	66
Figure 35: current measurement I (general, UTI-6)	71
Figure 36: current measurement II (UTI-6)	71
Figure 37: unipolar sensor supply 5 V to 15 V (UTI-6)	71
Figure 38: unipolar sensor supply 24 V (UTI-6)	71
Figure 39: 3-wire sensor and bipolar sensor supply $\pm 15 \text{ V}$ (UTI-6)	71
Figure 40: UTI-6 with a non-isolated transducer in the sensor	74
Figure 41: UTI-6 with isolated transducer in the sensor	74
Figure 42: Socket for the power supply	107
Figure 43: Remote socket	107
Figure 44: GPS socket (base unit)	108
Figure 45: Socket to connect CANFT modules	108
Figure 46: B-4 socket (pinning)	109
Figure 47: UTI-6 socket (pinning)	109
Figure 48: ICPU-6 socket (pinning)	109

Index

4

4 segment LED display 25

A

Accessing the data carrier 29

Accessories 41

Add device 36

adjustment 6

ARGFT

B-4 pinning 109

Base 107

CAN FD 110

Fiber Converter 21

ICPU-6 pinning 109

UPS-NiMH 22

UTI-6 pinning 109

B

B-4 64

bridge measurement 64

sensor supply 66

Technical Specs 86

voltage measurement 69

Base

LED 30

Technical Specs 81

Baud rate 18

bridge measurement

B-4 64

C

Cables 8

calibration 6

CAN bus

Technical Specs 105

CAN FD 105

PvCAN 76

terminator 76

CAN Termination 19

CAN-Bus

cabling 76

Pin configuration 110

Power via CAN 110

Terminator 76

Transfer rate 76

Y-adaptor 76

CANSAS software 18

CANSASfit (CANFT) 18

CE 8

CE Certification 6

Certificates 6

Change of the length 55

Change of the resistance 55

Change requests 6

Cleaning 32

Click mechanism 17

Cluster size

FAT32 28

color-coding thermocouples 54

connect device 34

Connecting via LAN 34

Copy data to the PC 27

Customer support

Tech support 6

D

Data transfer 27

Password 27

Storage medium 27

Device

add 36

connect 34

Device certificate 32

Device group 38

Device overview 38

Diagonal bridge

temperature compensated 60

Diagonal bridge with two strain gauges in uniaxial direction 60

Dimensions 40

DIN-EN-ISO-9001 6

Drawings 40

E

Elastic modulus 55

ElektroG 8

EMC 7

energy sources 10

F

FCC 8

Fiber Converter

Technical Specs 101

File System

FAT32 28

Filter

concept 45

settings 45

theoretical background 45

Filter setting

- Filter setting
 - "Filter type: AAF" 49
 - "Filter type: low pass" 50
 - "Filter type: without" 53
 - Filter type
 - AAF 49
 - low pass 50
 - without 53
 - Firmware update 36
 - formatting 28
 - Full bridge 63
 - Bending 61
 - Poisson half bridge 62
 - strain installed on one side of the structure 62
 - Torsion measurement 63
 - Full bridge - general strain gauge
 - General 63
 - Full bridge consisting of two Poisson half bridges - installed on one side of the structure 62
 - Full bridge consisting of two Poisson half bridges - installed on opposite sides of the structure 62
 - Full bridge with four strain gauges - bending beam 61
- G**
- Gauge factor 55
 - General terms and conditions 6
 - GPS
 - process vector variables 42
 - RS232 settings 43
 - Grounding 20
 - Group
 - Device overview 38
 - Guarantee 6, 7
- H**
- Half bridge 61
 - Bending beam circuit 59
 - Diagonal bridge 60
 - Diagonal bridge - temperature compensated 60
 - Poisson half bridge 59
 - tension compression bar 60
 - Half bridge - general strain gauge
 - General 61
 - Half bridge with two strain gauges in uniaxial direction 59
 - Hard drive 27
 - Hotline
 - Tech support 6
 - how to connect 17
- I**
- ICPU-6
 - Pin configuration 109
 - Technical Specs 96
 - imc STUDIO 33
 - operating system 33
 - Industrial safety 12
 - Industrial safety regulation 12
 - Installation
 - imc STUDIO 33
 - Internal storage media 27
 - IP address
 - configure 34
 - of the devices 34
 - of the PCs 34
 - ISO-9001 6
 - Issues
 - Storage medium 29
- K**
- k factor 55
- L**
- Leads 8
 - LED
 - B-4 87
 - Base 30
 - Fiber Converter 102
 - ICPU-6 97
 - Power (UPS) module 25
 - UTI 92
 - Liability restrictions 7
 - Limitations
 - Storage medium 29
 - Limited Warranty 6
- M**
- Maintenance 6, 32
 - measurement mode
 - temperature 54
 - Memory card 27
 - Memory cards 38
 - microSD Storage medium 27
 - module connector 17
- N**
- NMEA 42
 - NMEA Talker IDs
 - GA, GB, GI, GL 43
 - GN, GP, GQ 43
- O**
- Operating personnel 11
 - Original length 55

P

- partition 28
- Password
 - Data transfer 27
- Pin configuration
 - B-4 109
 - CAN FD 110
 - CANSAS 108
 - GPS 108
 - ICPU-6 109
 - Power 107
 - Remote 107
 - UTI-6 109
- Poisson half bridge 59
 - Full bridge consisting of two Poisson half bridges 62
- Power off 26
- Power on 26
- Power supply 20
- Power-via-CAN 76
- Problems
 - Storage medium 29
- process vector variables
 - GPS 42
- Product improvement 6
- Pt100 54
- PvCAN 76

Q

- Quality Management 6
- Quarter bridge
 - external completion 58
 - internal completion 57
 - temperature compensated 58
- Quarter bridge with external completion resistor 58
- Quarter bridge with internal completion resistor 57

R

- Receiver
 - GPS 42
- repair 6
- Resistance of the strain 55
- Restriction of Hazardous Substances 8
- RoHS 8
- RS232 settings
 - GPS 43

S

- Safe operation 16
- Select device with explorer 27
- sensor supply

- B-4 66
- UTI-6 74
- Service 32
 - Tech support 6
- service and maintenance 6
- service check 6
- Service form 32
- Software installation 33
- Special hazards 12
- Storage 32
- storage device
 - formatting 28
 - partition 28
- Storage media 27
- Storage medium
 - Cluster size 28
 - Data transfer 27
 - FAT32 28
 - File system 28
 - Filesize (maximum) 28
 - Issues 29
 - Limitations 29
 - microSD 27
 - Problems 29
- Strain 55
- Strain gauge 55
 - definition of terms 55
- Swapping the storage medium 27
- Symbols 9
- SYNC 44
- SYNC socket 44
- synchronization 44
- System requirements 33

T

- Tech support 6
- Technical Specs
 - B-4 86
 - Base 81
 - CAN bus 105
 - Fiber Converter 101
 - ICPU-6 96
 - UPS-NiMH 103
 - UTI-6 91
- Telephone numbers
 - Tech support 6
- temperatur characteristic curve
 - How to select? 54
- temperature measurement 54
- temperature table 54
- Terminator

Terminator
 CAN 76
thermocouples 54
thermocouples color-coding 54
Time counter
 GPS 42
Torsion measurement 63
Transfer rate
 CAN 76
Transport 32
Transverse strain coeff. 55

U

UPS-NiMH
 Technical Specs 103
USB 27
UTI-6 70
 Current measurement 71
 Resistance measurement 72
 RTD measurement 73
 sensor supply 74
 Technical Specs 91
 voltage measurement 70

V

voltage measurement
 B-4 69
 UTI-6 70

W

Warranty 6
Waste on Electric and Electronic Equipment 8
WEEE
 Restriction of Hazardous Substances 8

Y

Y-adaptor
 CAN-Bus 76



An Axiometrix Solutions Brand

Contact imc

Address

imc Test & Measurement GmbH
Voltastr. 5
13355 Berlin

Phone: (Germany): +49 30 467090-0

E-Mail: info@imc-tm.de

Internet: <https://www.imc-tm.com>

Tech support

If you have problems or questions, please contact our tech support:

Phone: (Germany): +49 30 467090-26

E-Mail: hotline@imc-tm.de

Internet: <https://www.imc-tm.com/service-training/>

imc ACADEMY - Training center

The safe handling of measurement devices requires a good knowledge of the system. At our training center, experienced specialists are here to share their knowledge.

E-Mail: schulung@imc-tm.de

Internet: <https://www.imc-tm.com/service-training/imc-academy>

International partners

You will find the contact person responsible for you in our overview list of imc partners:

Internet: <https://www.imc-tm.com/imc-worldwide/>

imc @ Social Media

<https://www.facebook.com/imcTestMeasurement>

<https://www.youtube.com/c/imcTestMeasurementGmbH>

https://twitter.com/imc_de

<https://www.linkedin.com/company/imc-test-&-measurement-gmbh>