

## ISOF-8 for imc CRONOSflex (CRFX/ISOF-8)

### 8-channel, fast and isolated differential amplifier

The ISOF-8 is an isolated differential measurement amplifier with 8 galvanically-isolated channels for highly accurate measurements of:

- Voltage and current (20 mA)
- Temperature (Thermocoupe and PT100)
- IEPE/ICP sensors (with optional DSUB plug)

### Highlights

- Channel-wise isolated, galvanically-separated inputs
- Finely adjustable input voltage range (from  $\pm 25$  mV to  $\pm 60$  V)
- High signal bandwidth up to 48 kHz
- Each channel with its own adjustable filter (e.g., anti-aliasing filter) and simultaneous A/D converter
- Supports imc Plug & Measure (Transducer Electronic Data Sheets)



CRFX/ISOF-8 (Fig. similar) module shown in standard operating orientation

### Typical applications

- Ideally suited for measurements with unclear potential conditions such as in-vehicle or in the railway sector with higher bandwidths.

### imc CRONOSflex - Frameless expansion, flexible modularity

The imc Click Mechanism and extruded aluminum case provide a firm mechanical and electrical connection. As a result, no mainframe or rack is needed.

An imc CRONOSflex system uses EtherCAT as an "internal" system bus for connecting various modules to the main base unit (CRFX-400 / CRFX-2000G). With the system bus, all imc CRONOSflex modules are guaranteed to be synchronized with each other. This allows various modules to be either connected in one central block or connected via standard network cable in a spatially distributed system.

Alternatively, connection can be made by means of standard Ethernet cables (RJ45, CAT5), thus creating a spatially distributed system.



imc Click Mechanism



CRFX distributed system

### Overview of available variants

Standard version		ET version *	
Order code:	article no.	article no.	remarks
CRFX/ISOF-8	11900105	11910082	with DSUB-15 sockets
CRFX/ISOF-8-SUPPLY	11900155	11910098	with sensor supply
CRFX/ISOF-8-L	11900249	119100XX	with LEMO sockets
CRFX/ISOF-8-L-SUPPLY	11900228	11910135	with sensor supply

\* ET: Version in extended temperature range

### Mechanical drawings with dimensions

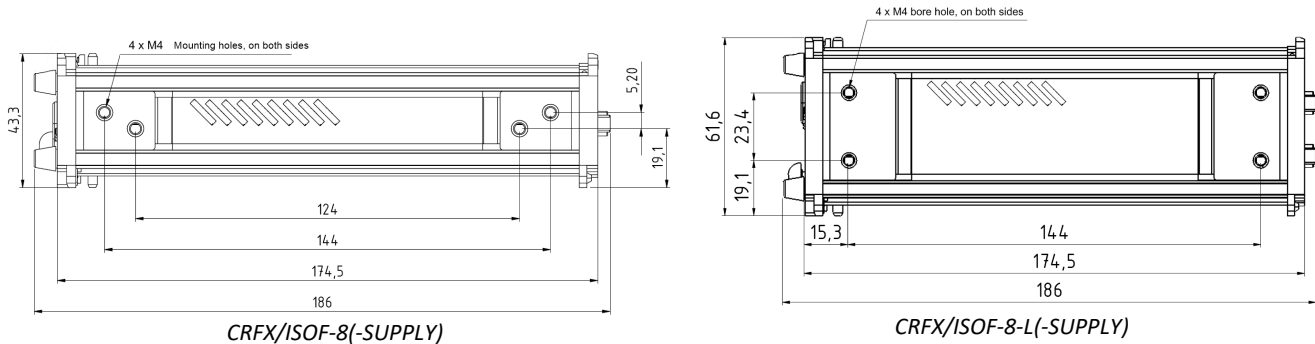

### Module power supply options

- Direct connection (LEMO.EGE.1B.302 power socket)
- Adjacent module (module connector / imc Click Mechanism)
- EtherCAT network cable: Power over EtherCAT (PoEC)

For further details refer to the power options documentation.

### Integrated sensor supply

- Version with an integrated sensor supply, requires no extra module expansion. With adjustable supply voltages (globally selectable for 8 channels), output on reserved pins.

### Included accessories

DSUB-15 plug	for the DSUB-15 variant	article no.
ACC/DSUBM-T4	DSUB-15 plug with screw terminals for 4-channel measurement of voltages as well as temperatures with PT100 and thermocouples with integrated cold junction compensation (CJC).	13500167

#### Documents

- Getting started with imc CRONOSflex (one copy per delivery)
- Device certificate

### Optional accessories

DSUB-15 plug		
ACC/DSUBM-TEDS-T4	T4 plug with TEDS support, according IEEE 1451.4 for use with imc Plug & Measure	13500190
ACC/DSUBM-U4	DSUB-15 plug with screw terminals for 4-channel voltage measurement.	13500166
ACC/DSUBM-TEDS-U4	U4 plug variant with TEDS support, according IEEE 1451.4 for use with imc Plug & Measure	13500189
ACC/DSUBM-I4	DSUB-15 plug with screw terminals for 4-channel current measurement of up to 50 mA (shunt 50 Ω, scaling factor 0.02 A/V)	13500168
ACC/DSUBM-TEDS-I4	I4 plug variant with TEDS support, according IEEE 1451.4 for use with imc Plug & Measure	13500192
ACC/DSUB-ICP4	DSUB-15 plug with screw terminals for conditioning of 4 IEPE/ICP inputs	13500032

<b>DSUB-15 plug</b>		
ACC/DSUBM-ICP2I-BNC-S	DSUB-15 plug for 2 IEPE/ICP sensors <sup>1</sup> , BNC connection, isolated, <b>slow</b>	13500293
ACC/DSUBM-ICP2I-BNC-F	DSUB-15 plug for 2 IEPE/ICP sensors <sup>1</sup> , BNC connection, isolated, <b>fast</b>	13500294
<b>AC/DC power adaptor 110-230 VAC 50-60 Hz (with appropriate LEMO.1B.302 plug)</b>		article no.
48 V DC / 150 W	ACC/AC-ADAP-48-150-1B	13500148
24 V DC / 60 W	CRPL/AC-ADAPTER-60W-1B	10800066
<b>Power plugs</b>		
ACC/POWER-PLUG-5	Power plug for DC supply LEMO.FGE.1B.302 plug (male, E-coded: 2 coding keys)	13500150
CRFX/MODUL-PP-90	Power plug for DC supply 90° angular LEMO.FHE.1B.302 plug (male, E-coded: 2 coding keys)	11900074
<b>Supply module (Power Handle)</b>		article no.
CRFX/HANDLE-POWER-L	Handle with system power supply 50 V 100 W, without UPS	11900058
CRFX/HANDLE-NIMH-L	Handle with system power supply 50 V 100 W, UPS with NiMH battery	11900273
CRFX/HANDLE-LI-IO-L	Handle with system power supply 50 V 100 W, UPS with Li-Ion battery	11900010
<b>Passive-Handle</b>		
CRFX/HANDLE-L	standard unpowered left handle	11900008
CRFX/HANDLE-R	standard unpowered right handle	11900007
<b>Mounting bracket for increased stability (recommended for lifetime and robustness)</b>		
CRFX/BRACKET-CON	assembly element for 2 modules	11900071
<b>Mounting brackets for fixed installations</b>		
CRFX/BRACKET-90	mounting bracket 90°	11900068
CRFX/BRACKET-180	mounting bracket 180°	11900069
CRFX/BRACKET-BACK	rear panel mounting element	11900070
CRFX/RACK	19" RACK for imc CRONOSflex Modules	11900066
CRFX/BRACKET-RACK	mounting element in the RACK	11900072
<b>Documents</b>		
SERV/CAL-PROT	Calibration protocol per amplifier imc manufacturer calibration certificate with measurement values and list of calibration equipment used (pdf).	150000566
SERV/CAL-PROT-PAPER	Calibration protocol per amplifier (paper print) imc manufacturer calibration certificate with measurement values and list of calibration equipment used with signature and seal.	150000578
Device certificates and calibration protocols: Detailed information on certificates supplied, the specific contents, underlying standards (e.g. ISO 9001 / ISO 17025) and available media (pdf etc.) can be found on our website, or you can contact us directly.		

- 
- 1 When using the 2-channel plug only two channels (first and third channel) out of four are usable.

### Technical Specs - CRFX/ISOF-8

Inputs, measurement modes, terminal connection		
Parameter	Value	Remarks
Inputs	8	
Measurement modes DSUB-15	voltage measurement current measurement thermocouple, RTD (PT100) current fed sensors IEPE/ICP	shunt plug (ACC/DSUBM-I4) thermo plug (ACC/DSUBM-T4) IEPE/ICP expansion plug (ACC/DSUB-ICP4, not isolated ACC/DSUBM-ICP2I-BNC-S/-F <sup>1</sup> , isolated)
Measurement modes LEMO	voltage measurement current measurement RTD (PT100)	differential (internal shunt)
Terminal connection Standard	2x DSUB-15 or	4 channels per plug
LEMO	8x LEMO.1B.307	1 channel per plug
Sampling rate, bandwidth, filter, TEDS		
Parameter	Value	Remarks
Sampling rate	≤100 kHz	per channel, max system throughput of all module channels: 800 kHz including monitor channels
Bandwidth	0 Hz to 48 kHz 0 Hz to 46 kHz	-3 dB -0.2 dB
Filter (digital) cut-off frequency characteristic order	10 Hz to 20 kHz	Butterworth, Bessel low pass filter: 8th order high pass filter: 8th order band pass: LP 4th and HP 4th order Anti-aliasing filter: Cauer 8.order with $f_{cutoff} = 0.4 f_a$
Resolution	16 Bit 24 Bit	output format is selectable for each channel individually: a) 16 Bit Integer b) 32 Bit Float (24 Bit Mantissa)
TEDS - Transducer Electronic Data Sheets	conforming to IEEE 1451 Class II MMI	esp. with ACC/DSUBM-TEDS-xx (DS2433) not supported DS2431 (typ. IEPE/ICP sensor)
Characteristic curve linearization	user defined (max. 1023 supporting points)	

- 1 When using the two-channel IEPE plug in combination with the analog inputs, which provide four channels per socket, only channels 1 and 3 can be used. Only the IEPE base functionality is supported by this module, see also TD ACC/DSUBM-ICP2I-BNC.

General			
Parameter	Value typ.	min. / max.	Remarks
Isolation	galvanically isolated		channel-to-channel and against system ground (housing, CHASSIS), as well as against common reference of all PT100 current sources and TEDS.
nominal rating	±60 V		Isolation with IEPE/ICP connector: depends on plug type
test voltage	±300 V (10 sec.)		
Overvoltage protection	±100 V ESD 2 kV transient protection: automotive load dump ISO 7637		differential input voltage (continuous) human body model  $R_f=30 \Omega$ , $t_d=300 \mu s$ , $t_r<60 \mu s$
Input coupling	DC		
Input configuration	differential, isolated		
Input impedance	6,7 M $\Omega$ 1 M $\Omega$ 50 $\Omega$		range $\leq \pm 2$ V or temperature mode range $\geq \pm 5$ V or device powered down current mode (shunt-plug) (ACC/DSUBM-I4)
Input current		2.4 nA	for operation $ V_{in}  > 5$ V on ranges $< \pm 5$ V or device powered-down
operating conditions on overvoltage condition	1 mA		
Auxiliary supply			for IEPE/ICP plug
voltage	5 V	±5%	independent of optional sensor supply, short circuit proof power per DSUB-plug
available current	>0.26 A	>0.2 A	
internal impedance	1.0 $\Omega$	<1.2 $\Omega$	

Voltage measurement			
Parameter	Value typ.	min. / max.	Remarks
Input ranges	$\pm 60\text{ V} / \pm 50\text{ V} / \pm 25\text{ V} / \pm 10\text{ V}$ $\pm 5\text{ V} / \pm 2\text{ V} / \pm 1\text{ V} / \pm 500\text{ mV}$ $\pm 250\text{ mV} / \pm 100\text{ mV} / \pm 50\text{ mV} / \pm 25\text{ mV}$		
Gain error	<0.025%	<0.05%	of the measured value, at 25°C
Gain drift		30 ppm/K· $\Delta T_a$ 60 ppm/K· $\Delta T_a$	ranges $\leq \pm 2\text{ V}$ ranges $\geq \pm 5\text{ V}$ over full temperature range
Offset error	0.02 %	<0.05 %	of the range
Offset drift		2.5 ppm/K· $\Delta T_a$	over entire temperature range $\Delta T_a =  T_a - 25^\circ\text{C} $ ; with $T_a$ = ambient temperature
Nonlinearity	<120 ppm		
Input voltage noise	$2.6\ \mu\text{V}_{\text{rms}} / 22\ \mu\text{V}_{\text{pkpk}}$ $0.5\ \mu\text{V}_{\text{rms}} / 3.5\ \mu\text{V}_{\text{pkpk}}$ $0.1\ \mu\text{V}_{\text{pkpk}}$ 14 nV / $\sqrt{\text{Hz}}$		range $\pm 25\text{ mV}$ bandwidth 0.1 Hz to 48 kHz bandwidth 0.1 Hz to 1 kHz bandwidth 0.1 Hz to 10 Hz spectral noise density
CMRR (common mode rejection ratio) / IMR	>145 dB (50 Hz) >80 dB (50 Hz)		ranges $\leq \pm 2\text{ V}$ ranges $\geq \pm 5\text{ V}$ $R_{\text{source}} = 0\ \Omega$
Channel isolation	>1 G $\Omega$ , < 40 pF		channel-to-ground / CHASSIS (case)
	>1 G $\Omega$ , < 10 pF		channel-to-channel
Channel isolation (crosstalk)	>155 dB (50 Hz) >92 dB (50 Hz)		ranges $\leq \pm 2\text{ V}$ ranges $\geq \pm 5\text{ V}$ $R_{\text{source}} \leq 100\ \Omega$
Current measurement with shunt plug			
Parameter	Value typ.	min. / max.	Remarks
Input ranges	$\pm 40\text{ mA} / \pm 20\text{ mA} / \pm 10\text{ mA}$		
Shunt impedance	50 $\Omega$		external plug ACC/DSUBM-I4
Gain error	<0.07 %	<0.15 %	of the measured value, at 25 °C
Gain drift		30 ppm/K· $\Delta T_a$ 60 ppm/K· $\Delta T_a$	ranges $\leq \pm 2\text{ V}$ ranges $\geq \pm 5\text{ V}$ over full temperature range
Offset error	10 $\mu\text{V}$		range $\pm 25\text{ mV}$
Offset drift	0.7 $\mu\text{V}/\text{K}\cdot\Delta T_a$		range $\pm 25\text{ mV}$ $\Delta T_a =  T_a - 25^\circ\text{C} $ ; with $T_a$ = ambient temperature

Current measurement with internal shunt (variant with round connector etc.)			
Parameter	Value typ.	min. / max.	Remarks
Input ranges	±40 mA / ±20 mA / ±10 mA		
Shunt impedance	50 Ω		internal
Input configuration	differential		
Gain error	<0.02 %	<0.05 %	of the measured value, with 25°C
Gain drift		40 ppm/K·ΔT <sub>a</sub>	over entire temperature range
Offset error	0.02 %	<0.05 %	of the measurement range
Offset drift		2.5 ppm/K ·ΔT <sub>a</sub>	over entire temperature range ΔT <sub>a</sub> = T <sub>a</sub> -25°C ; with T <sub>a</sub> = ambient temperature

Temperature measurement - thermocouples			
Parameter	Value typ.	min. / max.	Remarks
Measurement mode	R, S, B, J, T, E, K, L, N		
Measurement range	-270°C bis 1370°C -270°C bis 1100°C -270°C bis 500°C		type K
Resolution	0.063 K (1/16 K) 32 bit float (24 Bit mantissa)		With selected data type / output format: a) 16-Bit integer b) Float (24-Bit mode)
Measurement error (gain + offset)		<±0.6 K <±1.0 K	type K, value -150°C to 1100°C else
Drift (gain + offset)		±0.02 K/K·ΔT <sub>a</sub> ±0.05 K/K·ΔT <sub>a</sub>	type K, range -270°C to 1100°C type K, range -270°C to 1370°C ΔT <sub>a</sub> = T <sub>a</sub> -25°C ; with T <sub>a</sub> = ambient temperature
Error of cold junction compensation		<±0.15 K	with ACC/DSUBM-T4
Cold junction drift	±0.001 K/K·ΔT <sub>a</sub>		ΔT <sub>a</sub> = T <sub>a</sub> -25°C ; with T <sub>a</sub> = ambient temperature

Temperature measurement – PT100			
Parameter	Value		Remarks
Measurement range	-200°C to +850°C -200°C to +250°C		
Resolution	0.063 K (1/16 K) 32 bit float (24 Bit mantissa)		With selected data type / output format: a) 16-Bit integer b) Float (24-Bit mode)
Measurement error	<±0.05%		of the measured value
Offset error	<±0.2 K		4-wire connection
Offset drift	±0.01 K/K·ΔT <sub>a</sub> ±0.02 K/K·ΔT <sub>a</sub>		range -200°C to 250°C range -200°C to 850°C ΔT <sub>a</sub> = T <sub>a</sub> -25°C ; with T <sub>a</sub> = ambient temperature
Sensor feed (PT100)	250 μA		Not channel individually isolated. global block isolation, common reference: -I4, GND, TEDS_GND



Sensor supply (ISOF-8-SUPPLY, ISOF-8-L-SUPPLY)				
Parameter	Value typ.		max.	Remarks
Configuration options	5 selectable settings			5 settings only Default ranges: +5 V to +24 V
Output voltage	Voltage (+2.5 V) +5.0 V +10 V +12 V +15 V +24 V (±15 V)	Current 580 mA 580 mA 300 mA 250 mA 200 mA 120 mA 190 mA	Netpower 1.5 W 2.9 W 3.0 W 3.0 W 3.0 W 2.9 W 3.0 W	set globally for all channels of a module special order, +12 V or 15 V can be replaced by +2.5 V; default selection with 2.5 V: +2.5 V, +5.0 V, +10 V, +12 V, +24 V  Special order: +15 V can be replaced by ±15 V. With the LEMO variant, TEDS support is omitted with this choice, LEMO pin 5 (TEDS) is then GND, pin 3 is +15 V and pin 4 -15 V, see manual.
Block isolation	60 V			Isolation of the entire global sensor supply (for all 8 channels, reference ground "-SUPPLY, GND") as well as the internal additional electronics from housing (CHASSIS, PE)
Short-circuit protection	unlimited duration			to output voltage reference ground
Accuracy of output voltage	<0.25 %		0.5 % 0.9 % 1.5 %	at terminals, no load at 25 °C over entire temperature range plus with optional bipolar output voltage
Max. capacitive load	>4000 µF >1000 µF >300 µF			2.5 V to 10 V 12 V, 15 V 24 V

Block isolation		
Parameter	Value	Remarks
Block isolation	60 V	all internal additional-electronics (PT100-current sources, TEDS, sensor supply) isolated from the housing (CHASSIS, PE)
Isolation impedance	500 kΩ    1 nF	
Internal reference ground	GND, TEDS_GND, -I4, -SUPPLY	PT100 current sources and TEDS for all channels with one common, galvanically connected reference ground
External reference ground	CHASSIS, metal housing	internal additional-electronics as an entity, galvanically isolated from housing

Block isolation for improved suppression of ground loops and related interference. Does not constitute channel-wise individual isolation. Not rated nor intended for safety of equipment and personnel.

Power supply of the module		
Parameter	Value	Remarks
Input supply voltage	10 V to 50 V DC	
Power consumption	10 W	10 V to 50 V DC
Isolation	60 V	nominal isolation specification of the supply input

Power supply of the module		
Power-over EtherCAT (PoEC)	42 V to 50 V DC	supply via EtherCAT network cable
Terminal connections of the module		
EtherCAT connection	2x RJ45	system bus for distributed imc CRONOSflex components
Input supply plug (female)	LEMO.EGE.1B.302	multicoded 2 notches for optional individually power supply
Module connector	2x 20 pin	direct connection of modules (click) supply and system bus
Pass through power limits		
Directly connected (clicked) imc CRONOSflex Modules	3.1 A (maximum current) Equivalent power with chosen DC power input: <ul style="list-style-type: none"> <li>• 149 W @ 48 V DC (e.g. AC/DC line adaptor)</li> <li>• 37 W @ 12 V DC (typical vehicle supplied DC input)</li> </ul>	
Power-over EtherCAT (PoEC) for remote modules	350 mA (maximum current corresponding to IEEE 802.3) Equivalent power with chosen DC power input: <ul style="list-style-type: none"> <li>• 17.5 W @ 50 V DC (e.g. Power-Handle)</li> <li>• 16.8 W @ 48 V DC (e.g. AC/DC line adaptor)</li> <li>• 14.7 W @ 42 V DC (minimum voltage for PoEC)</li> </ul> Note: minimum system power of 42 V DC required for PoEC	
Operating conditions		
Parameter	Value	Remarks
Operating environment	dry, non corrosive environment within specified operating temperature range	
Rel. humidity	80% up to 31°C, above 31°C: linear declining to 50%	according IEC 61010-1
Ingress protection rating	IP20	
Pollution degree	2	
Operating temperature (standard)	-10°C to +55°C	without condensation
Operating temperature (extended: "-ET" version)	-40°C to +85°C	condensation temporarily allowed
Shock- and vibration resistance	IEC 61373, IEC 60068-2-27 IEC 60062-2-64 category 1, class A and B MIL-STD-810 Rail Cargo Vibration Exposure U.S. Highway Truck Vibration Exposure	
Extended shock- and vibration resistance	upon request	specific tests or certifications upon request
Dimensions	43.3 x 118 x 186 mm	W x H x D
Weight	714 g	