

ISO2-8(-16)-2T for imc CRONOSflex (CRFX)

8- or 16-channel, isolated measurement amplifier for thermocouples

This imc CRONOSflex Measurement Module is equipped with 8 (CRFX/ISO2-8-2T) or with 16 (CRFX/ISO2-16-2T) isolated channels for the measurement of thermocouples of type K.

Highlights

- complete channel individual isolation and conditioning (filter, ADC)
- high bandwidth for acquisition of dynamic processes
- direct connection of thermocouples type K via miniature thermocouple terminal connector



CRFX/ISO2-8-2T



CRFX/ISO2-16-2T

imc CRONOSflex- Frameless expansion, flexible modularity

The imc Click Mechanism and extruded aluminum case provide a firm mechanical and electrical connection. As a result, no mainframe or rack is needed.

An imc CRONOSflex system uses EtherCAT as an "internal" system bus for connecting various modules to the main base unit (CRFX-400 / CRFX-2000G). With the system bus, all imc CRONOSflex modules are guaranteed to be synchronized with each other. This allows various modules to be either connected in one central block or connected via standard network cable in a spatially distributed system.

Alternatively, connection can be made by means of standard Ethernet cables (RJ45, CAT5), thus creating a spatially distributed system.



imc Click Mechanism



CRFX distributed system

Overview of available variants

Standard version		ET-version *	
Order Code:	article no.	article no.	remarks
CRFX/ISO2-8-2T	11900073	11910100	with miniature thermocouple sockets
CRFX/ISO2-16-2T	11900104	11910095	with 16 miniature thermocouple sockets

* ET: Version for an extended temperature range

Mechanical drawings with dimensions

apply to both CRFX/ISO2-8-2T and CRFX/ISO2-16-2T

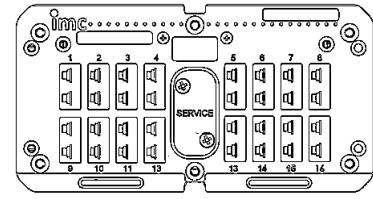
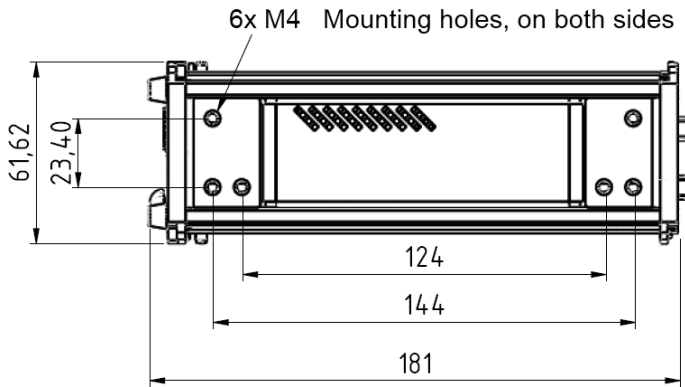

front view: CRFX/ISO2-16-2T

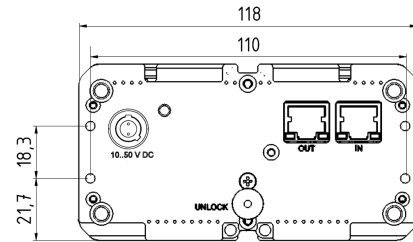

rear view

Module power supply options

- Direct connection (LEMO.EGE.1B.302 power socket)
- Adjacent module (module connector / imc Click Mechanism)
- EtherCAT network cable: Power over EtherCAT (PoEC)

For further details refer to the power options documentation.

Included accessories

Documents
Getting started with imc CRONOSflex (one copy per delivery)
Device certificate

Optional accessories

AC/DC power adaptor 110-230 VAC 50-60 Hz (with appropriate LEMO.1B.302 plug)		article no.
48 V DC / 150 W	ACC/AC-ADAP-48-150-1B	13500148
24 V DC / 60 W	CRPL/AC-ADAPTER-60W-1B	10800066
Power plugs		
ACC/POWER-PLUG-5	Power plug for DC supply LEMO.FGE.1B.302 plug (male, E-coded: 2 coding keys)	13500150
CRFX/MODUL-PP-90	Power plug for DC supply 90° angular LEMO.FHE.1B.302 plug (male, E-coded: 2 coding keys)	11900074
Supply module (Power Handle)		article no.
CRFX/HANDLE-POWER-L	Handle with system power supply 50 V 100 W, without UPS	11900058
CRFX/HANDLE-NIMH-L	Handle with system power supply 50 V 100 W, UPS with NiMH battery	11900273
CRFX/HANDLE-LI-IO-L	Handle with system power supply 50 V 100 W, UPS with Li-Ion battery	11900010

Passive-Handle		
CRFX/HANDLE-L	standard unpowered left handle	11900008
CRFX/HANDLE-R	standard unpowered right handle	11900007
Mounting bracket for increased stability (recommended for lifetime and robustness)		
CRFX/BRACKET-CON	assembly element for 2 modules	11900071
Mounting brackets for fixed installations		
CRFX/BRACKET-90	mounting bracket 90°	11900068
CRFX/BRACKET-180	mounting bracket 180°	11900069
CRFX/BRACKET-BACK	rear panel mounting element	11900070
CRFX/RACK	19" RACK for imc CRONOSflex Modules	11900066
CRFX/BRACKET-RACK	mounting element in the RACK	11900072
Documents		
SERV/CAL-PROT	Calibration protocol per amplifier imc manufacturer calibration certificate with measurement values and list of calibration equipment used (pdf).	150000566
SERV/CAL-PROT-PAPER	Calibration protocol per amplifier (paper print) imc manufacturer calibration certificate with measurement values and list of calibration equipment used with signature and seal.	150000578
Device certificates and calibration protocols: Detailed information on certificates supplied, the specific contents, underlying standards (e.g. ISO 9001 / ISO 17025) and available media (pdf etc.) can be found on our website, or you can contact us directly.		

Technical Specs - CRFX/ISO2-8-2T and ISO2-16-2T

Channels, measurement modes, terminal connection		
Parameter	Value	Remarks
Channels	8 16	ISO2-8-2T ISO2-16-2T
Measurement mode	temperature measurement thermocouples type K	
Terminal connection Measurement input	miniature thermocouple terminal connector	2-pin, female
EtherCAT connection	2x RJ45	system bus for distributed imc CRONOSflex components
Input supply plug (female)	LEMO.EGE.1B.302	multicoded 2 notches for optional individually power supply
Module connector	2x 20-pin	direct connection of modules (click) supply and system bus
Sampling rate, Bandwidth, Filter		
Parameter	Value	Remarks
Sampling rate	≤10 kHz	per channel, max system throughput of all module channels: 800 kHz including monitor channels
Bandwidth	0 Hz to 1 kHz 0 Hz to 2 kHz	-0.1 dB ISO2-8-2T -0.1 dB ISO2-16-2T
Resolution	16 Bit 24 Bit	output format is selectable for each channel individually: a) 16 Bit Integer b) 32 Bit Float (24 Bit Mantissa)
Filter (digital) cut-off frequency, characteristic, order	2 Hz to 500 Hz CRFX/ISO2-16-2T 2 Hz to 5 kHz CRC/CRFX/ISO2-8-2T	Butterworth, Bessel low pass filter: 8th order high pass filter: 4th order band pass: LP 8th and HP 4th order Anti-aliasing filter: Cauer 8.order with $f_{\text{cutoff}} = 0.4 f_a$

Temperature measurement - thermocouples			
Parameter	Value typ.	min. / max.	Remarks
Measurement range	temperature range: -200°C to +1200°C type K		
Resolution	0.063 K (1/16 K) 32 bit float (24 Bit mantissa)		With selected data type / output format: a) 16-Bit integer b) Float (24-Bit mode)
Measurement error		<±0.6 K <±1.0 K	type K, range -150°C to 1200°C type K, range -200°C to -150°C
Temperature drift	±0.02 K//K· T _a		T _a = T _a -25°C ; with T _a = ambient temperature
Error of cold junction compensation		<±0.15 K	
Temperature drift	±0.001 K//K· T _j		T _j = T _j -25°C ; with T _j = cold junction temperature

General			
Parameter	Value	Remarks	
Isolation	galvanically isolated	channel-to-channel and against system ground (housing, CHASSIS, PE)	
nominal rating	±60 V	channel to case	
test voltage	±300 V (10 sec.)		
Overvoltage protection	±60 V ESD 2 kV transient protection: automotive load dump ISO 7637	differential input voltage (continuous) human body model R _i =30 Ω, t _d =300 μs, t _r <60 μs	
Input coupling	DC		
Input configuration	differential, isolated	galvanically isolated to System-GND (housing, CHASSIS)	
Input impedance	6.7 M		

Power supply of the module			
Parameter	Value	Remarks	
Input supply voltage	10 V to 50 V DC		
Power consumption	10 W	10 V to 50 V DC	
Isolation	60 V	nominal isolation specification of the supply input	
Power-over EtherCAT (PoEC)	42 V to 50 V DC	supply via EtherCAT network cable	

Pass through power limits	
Directly connected (clicked) imc CRONOSflex Modules	3.1 A (maximum current) Equivalent power with chosen DC power input: <ul style="list-style-type: none"> • 149 W @ 48 V DC (e.g. AC/DC line adaptor) • 37 W @ 12 V DC (typical vehicle supplied DC input)
Power-over EtherCAT (PoEC) for remote imc CRONOSflex Modules	350 mA (maximum current corresponding to IEEE 802.3) Equivalent power with chosen DC power input: <ul style="list-style-type: none"> • 17.5 W @ 50 V DC (e.g. Power-Handle) • 16.8 W @ 48 V DC (e.g. AC/DC line adaptor) • 14.7 W @ 42 V DC (minimum voltage for PoEC) Note: minimum system power of 42 V DC required for PoEC

Operating conditions		
Parameter	Value	Remarks
Operating environment	dry, non corrosive environment within specified operating temperature range	
Rel. humidity	80% up to 31°C, above 31°C: linear declining to 50%	according IEC 61010-1
Ingress protection rating	IP20	
Pollution degree	2	
Operating temperature (standard)	-10°C to +55°C	without condensation
Operating temperature (extended: "-ET" version)	-40°C to +85°C	condensation temporarily allowed
Shock- and vibration resistance	IEC 61373, IEC 60068-2-27 IEC 60062-2-64 category 1, class A and B MIL-STD-810 Rail Cargo Vibration Exposure U.S. Highway Truck Vibration Exposure	
Extended shock- and vibration resistance	upon request	specific tests or certifications upon request
Dimensions	62 x 118 x 186 mm	W x H x D
Weight	approx. 1.1 kg	



An Axiometrix Solutions Brand

Contact imc

Address

imc Test & Measurement GmbH
Voltastr. 5
13355 Berlin

Phone: (Germany): +49 30 467090-0

E-Mail: info@imc-tm.de

Internet: <https://www.imc-tm.com>

Tech support

If you have problems or questions, please contact our tech support:

Phone: (Germany): +49 30 467090-26

E-Mail: hotline@imc-tm.de

Internet: <https://www.imc-tm.com/service-training/>

imc ACADEMY - Training center

The safe handling of measurement devices requires a good knowledge of the system. At our training center, experienced specialists are here to share their knowledge.

E-Mail: schulung@imc-tm.de

Internet: <https://www.imc-tm.com/service-training/imc-academy>

International partners

You will find the contact person responsible for you in our overview list of imc partners:

Internet: <https://www.imc-tm.com/imc-worldwide/>

imc @ Social Media

<https://www.facebook.com/imcTestMeasurement>

<https://www.youtube.com/c/imcTestMeasurementGmbH>

https://twitter.com/imc_de

<https://www.linkedin.com/company/imc-test-&-measurement-gmbh>